

## Feeder Protection From Over Load Situation through IoT

A.V.Sudhakara Reddy<sup>1</sup>, M.Laxmidevi Ramanaiah<sup>2</sup>, Y.V.Krishna Reddy<sup>3</sup>, B.Navya<sup>4</sup>, K.Hari Krishna<sup>5</sup>, A.Mahender<sup>6</sup>

<sup>1</sup>Asso. Prof.,EEE, Malla Reddy Engineering College (Autonomous), [sreddy4svu@gmail.com](mailto:sreddy4svu@gmail.com)

<sup>2</sup>Asso. Prof.,EEE, Institute of Aeronautical Engineering,  
Hyderabad,[m.laxmidevi@yahoo.com](mailto:m.laxmidevi@yahoo.com)

<sup>3</sup>Asst. Prof.,EEE, S.V.College of Engineering,Tirupati, India [yvkrishnareddy36@gmail.com](mailto:yvkrishnareddy36@gmail.com)

<sup>4</sup>UG Student,EEE, Malla Reddy Engineering College (Autonomous),  
[navyasribhaskara@gmail.com](mailto:navyasribhaskara@gmail.com)

<sup>5</sup>UG Student,EEE, Malla Reddy Engineering College (Autonomous),  
[harikrishnakokkula98@gmail.com](mailto:harikrishnakokkula98@gmail.com)

<sup>6</sup>UG Student,EEE, Malla Reddy Engineering College (Autonomous),  
[mahendaradepul@gmail.com](mailto:mahendaradepul@gmail.com)

Corresponding Author: A.V.Sudhakara Reddy

### ABSTRACT

*A bus bar in an electrical power distribution refers to bulky segments of copper or aluminum that carry out electricity within a switchboard, distribution panel and substation. In this task, bus bar can be protected from the over current condition. Mechanical instruments disappointments have numerous causes and one of the primary causes is over burden. The crucial of the distribution transformer is anticipated to work at assured particular current, if that current passing through that feeder is more than the rated then instantaneously the feeder may damaged because of over load, through this projected work we are departing to defend the bus bar from heavy load condition. In this work, more loads are applied to the circuit to produce high current. So that the current will be increased. At whatever point the over current happened the circuit will be tripped. Here, one relay is utilized which will control through our microcontroller to trip the circuit. Whenever over load is occurred relay will trip the whole circuit and buzzer will on control through our microcontroller to indicate over load. Whenever over load occurs micro controller automatically triggers the load to OFF and data will alert through IoT.*

**Index Terms** –IoT, Buzzer, Fault, Feeder Protection, Fuse, Microcontroller, Over Load, Relay and Smart Grid.

### 1.INTRODUCTION

In electric power distribution, a programmed protection of over burden of distribution network is an electrical circuit breaker equipped with an instrument that can naturally close the breaker subsequent to that it has been opened owing to a fault. Programmed over-burden security systems are used in coordinated protection schemes for overhead line power distribution networks. These circuits are horizontal to momentary faults such as overload and short circuit faults. A transient fault roots open the breaker contacts or gust the fuse with conservative circuit breaker or fuse, disabling the line awaiting a technical person could physically close the breaker or substitute the blown fuse. But a programmed overload protection system will make quite a few pre-automatic attempts to or bring back to healthy or strengthen the line.

In order to reduce the problem many design techniques can be found in literature [I],[II],[VII],[IX]. One of them is commonly used feeder protection & relay converters [III],[VII]. The power of a proposed design is very effective and reliable manner.

The upheaval has bring in the present world by Internet of Things (IoT) supported technology behind its innovatory in the pasture of PC and web. In this manner we can utilize the derivation of IoT innovation inside the grid. In distribution network, a modified programmable over-burden

safeguard system which is an electrical switch secured with a component that can lacking human intercession shuts the breaker after it has been unlocked owing to a fault. These networks are mostly laying face down to the transitory faults such as overload or short circuit faults. With mainstream fuse or breaker switch, a fault will open the breaker or blow the fuse. Thus immobilizes the line turn over a specialist can physically replace the gusted fuse or shuts the electrical switch i.e., breaker on. Be that as it may, the overload protection system can create numerous preprogrammed attempts consecutively to boost the line or recover the original network. The preliminary protection of feeders with fault clearing time as described is drawn in Fig. 1.

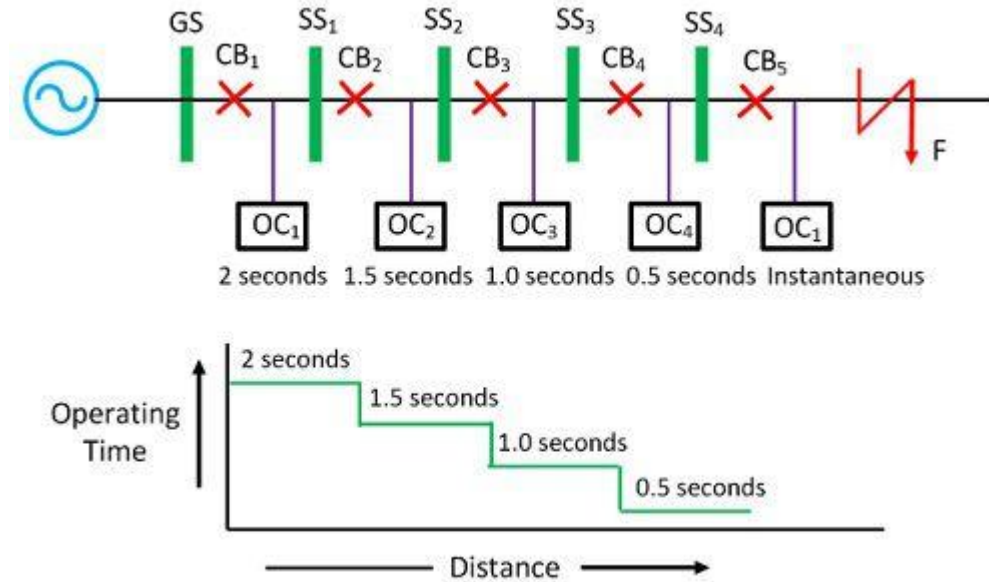

**Fig. 1 General Representation of protection of Feeders**

If the fault has been cleared then breaker circuit of the computerized over-load security system will keep on secured and power supply continues working. Today the world is moving quickly towards the more equipped and efficiently organized smart grid structure by subbing the present overworked proficiency with the smart grid technology which is illustrated in Fig. 2. So we can utilize both the information so as to make the near power system more functional and efficient. Smart grid and IoT is a portrait wonderful mixture of two, which will bring about upgrade of the current network configuration with feeders.

An embedded scheme is a combination of programming and equipment to play out to perform a devoted task. A portion of the fundamental devices utilized in embedded items are Micro-controllers and Micro-processors. Microprocessors are frequently referred to as general purpose processors as they merely recognize the efforts, process it and give the output. Interestingly, a microcontroller acknowledges the data as inputs as well as controls it, interfaces the data with a variety of devices to control the data and thus finally gives the output.

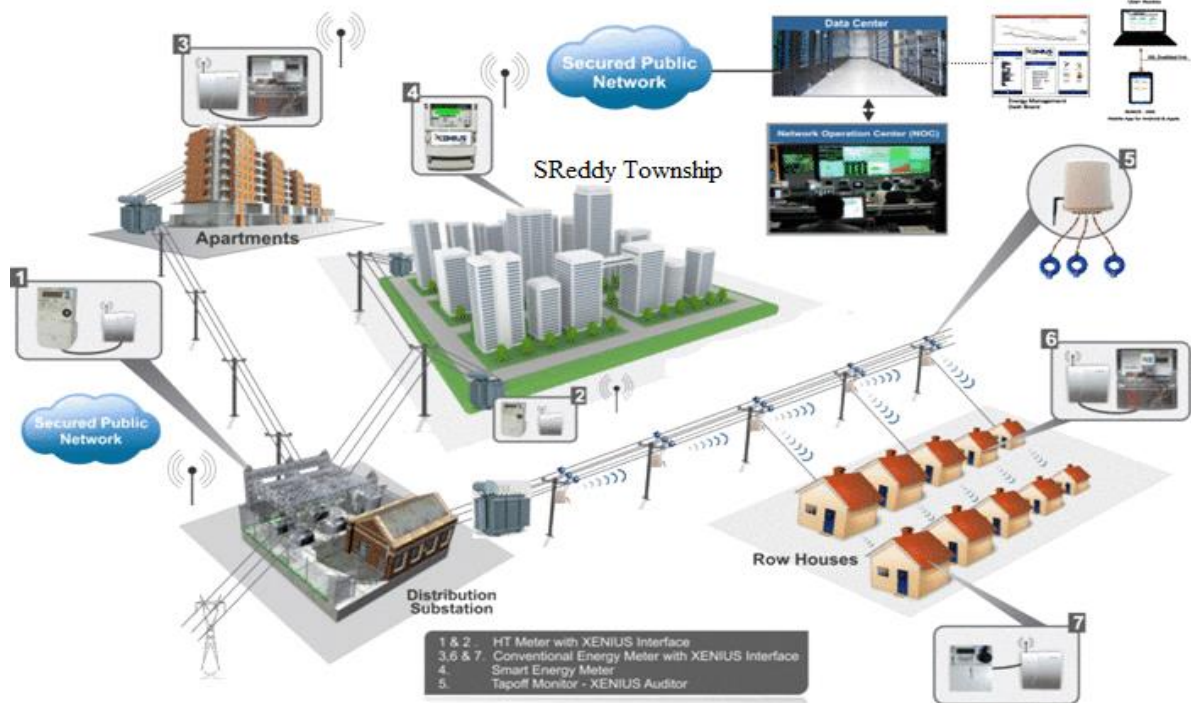

**Fig. 2 Feeders with Smart Grid**

## 2. TRADITIONAL SYSTEM

In existing power feeder network, load current is escalating in environment so it will directly pressure to the customers equipments and end user side end users. The protection of total system of Parallel Feeders as shown in Fig. 3.

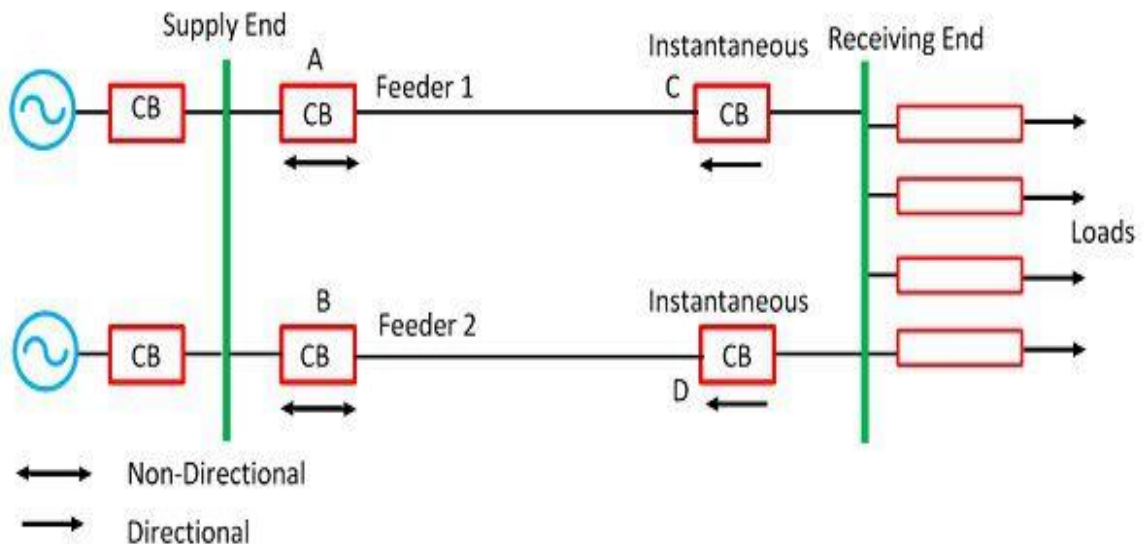

**Fig. 3 Protection of Parallel Feeders**

The equipment is associated in end user side will be collapse due to flow of over currents in the feeder streams. There is no precise controller is mounted on power lines for fault identification. The existing network will not be able to identify the faults like feeder overloading which reasons the load balancing problem of feeders for the reasons that of chances of failing the equipment owing to huge heavy load current.

### 3. IMPLEMENTATION OF PROPOSED SYSTEM

Here, Arduino used as a controller. If current sensor is sensed on the buzzer which will be displayed on LCD. Web server updated using IOT module and trip the relay bulb is OFF. POT is used if Voltage increased that time load will off. In order to implement, the system code is shown in Fig. 4. After sensing the fault, the microcontroller will sent signal to overload entity to trip the relay immediately. Also sends SMS through IOT module.

```
#include <LiquidCrystal.h>
#include <stdio.h>
LiquidCrystal lcd(6, 7, 5, 4, 3, 2);
int buzzer = 13;
int relay = 8;
int FS = A0
int POT = A2;
void beep()
{
digitalWrite(buzzer, LOW);
delay(1500);
digitalWrite(buzzer, HIGH);
}
void setup()
{
Serial.begin(9600);//serialEvent();
pinMode(POT, INPUT);
pinMode(FS, INPUT);
pinMode(buzzer, OUTPUT);
pinMode(relay, OUTPUT);
digitalWrite(buzzer, HIGH);
digitalWrite(relay, LOW);
lcd.begin(16, 2);
lcd.print("iot feeder over load alert");
lcd.setCursor(0, 1); //column,row
lcd.print("F:"); //3,1
```

**Fig. 4 Representation of pseudo code**

The compilation process is given in steps from Fig. 5 to Fig. 7 in a sequential manner.

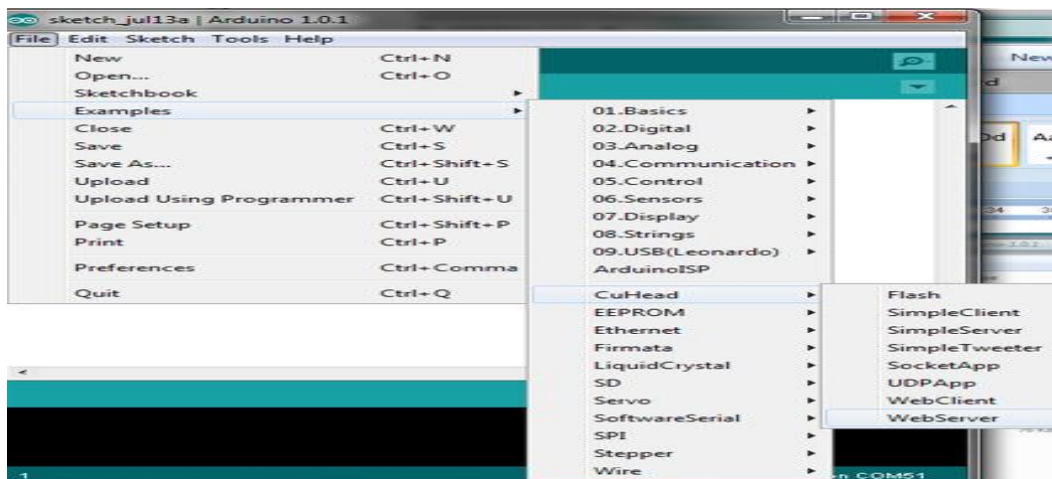

**Fig. 5 Compilation Process Step 1**

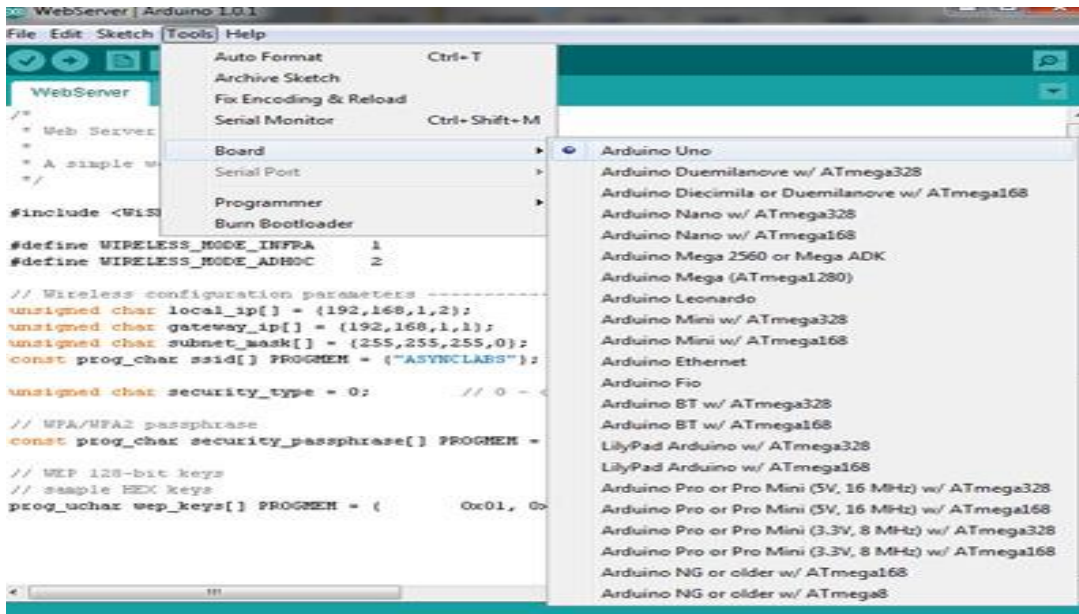

Fig. 6 Compilation Process Step 2

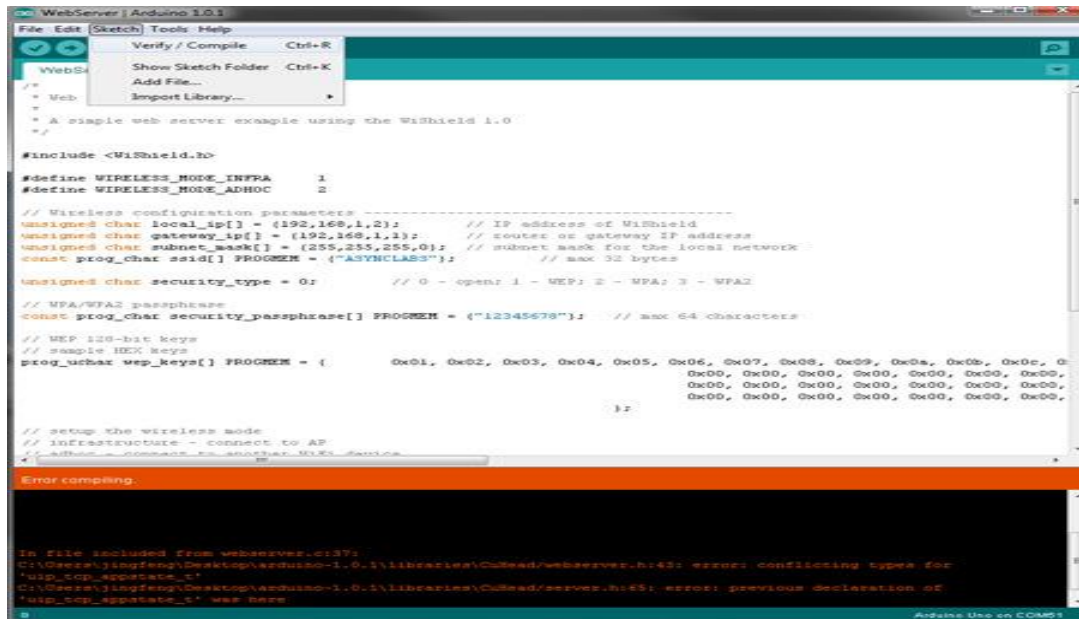

Fig. 7 Compilation Process Step 3

### Liquid Crystal Display (LCD)

A schematic diagram of conventional D-flip flop is illustrated in Fig.8.



Fig. 8 LCD Display

The microcontroller ARDUINO UNO is heart of our working model. Feeder protection from overload is the prototype modules which consist of ARDUINO UNO microcontrollers, current sensor, ADC 0808, relay module, 16\*2 LCD module, IOT module, Buzzer, Bulb, feeder supply and power supply. The automatic overload protection System circuit has a current sensing unit to detect the over current through the power line through potentiometers POT. A schematic diagram of conventional D-flip flop is illustrated in Fig.9.

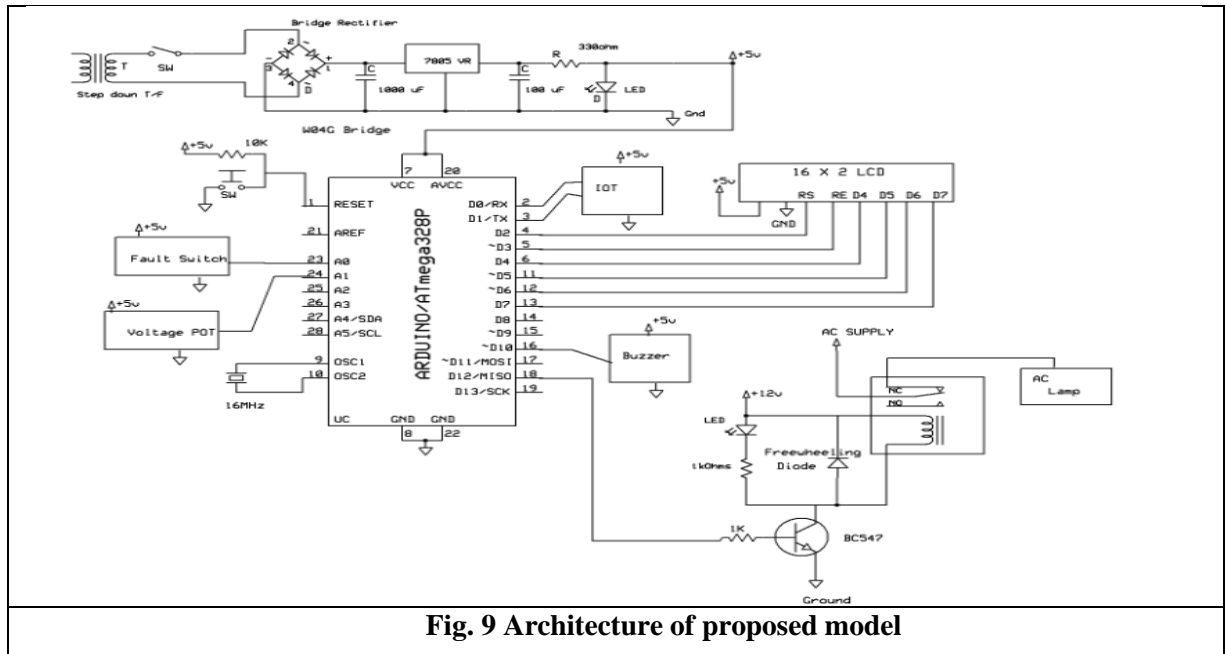
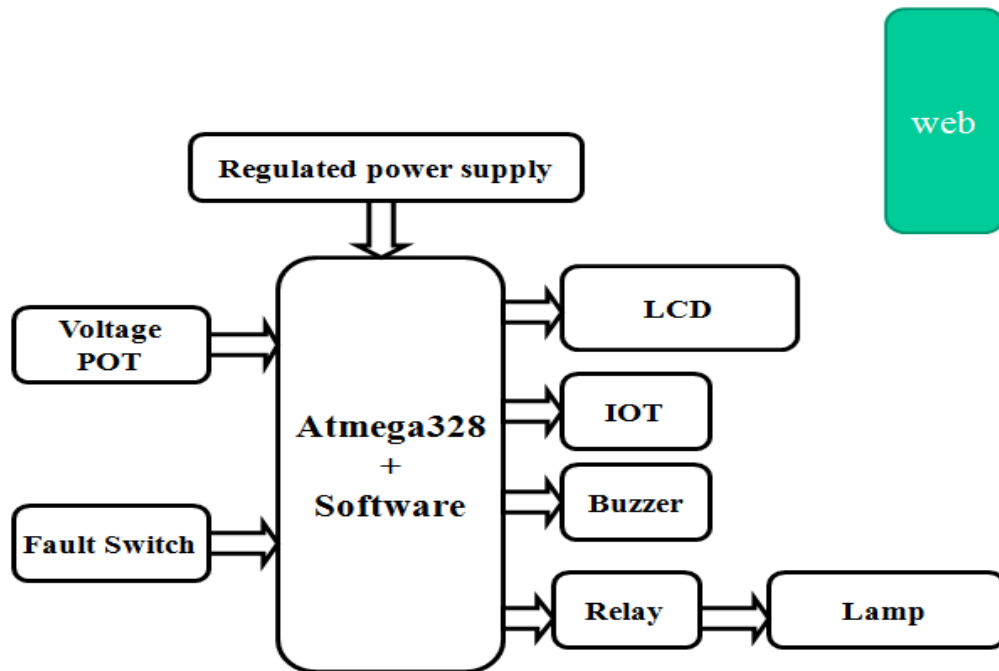

**Fig. 9 Architecture of proposed model**

The basic two reasons for the over current in a power line are overload and short circuit. So, when these faults occur the gives a signal to the line controller circuit. In this work, to produce high currents, more loads are relating to the network which will increases current. The current sensor in the system is associated in series with the power line and sense the current flow through the power line is to be tripped. To trip the circuit. Here, one relay is used to control through our microcontroller for tripping.

#### **4. WORKING PRINCIPLE**

In this section we are going to describe Block Diagram with Arduino for protection which is drawn in Fig. 10. The schematic of working model as shown in Fig. 11.



**Fig. 10 Block Diagram with Arduino Protection System**

**Advantages:**

- Controls high and low voltage levels
- Fast response
- Efficient and low cost design
- Low power consumption
- Long life

**Disadvantages:**

- Fast response based on signal for communication.

**Applications:**

- Industrial
- Power Generation
- SCADA Systems

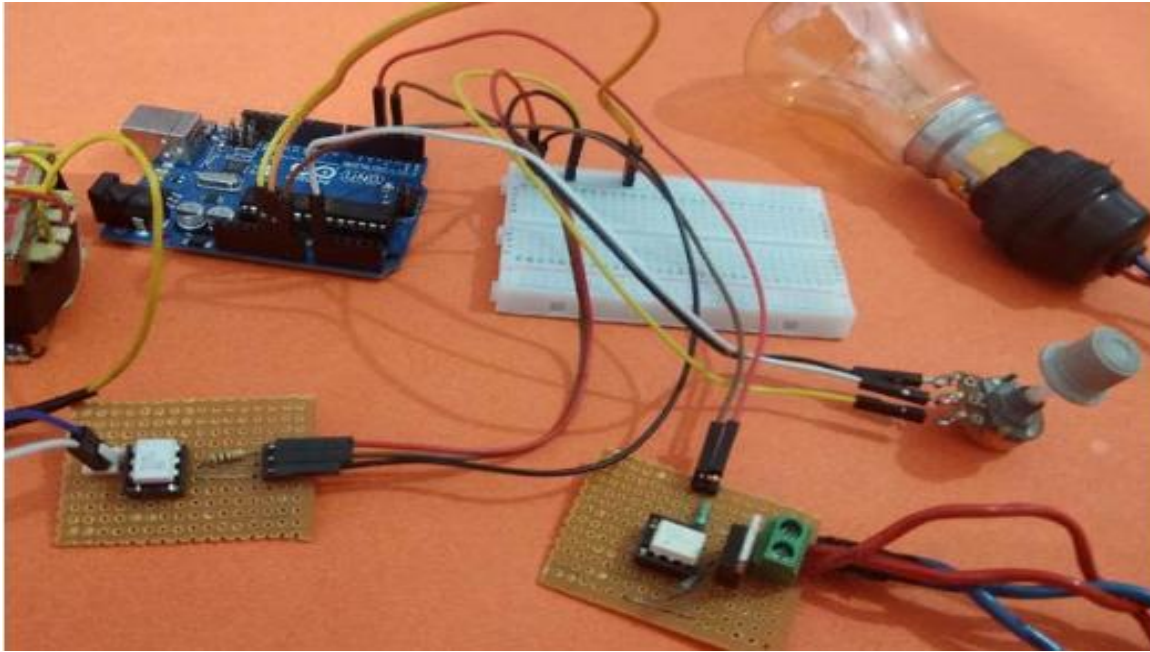

**Fig. 11 Schematic of Working Model**

## 5. CONCLUSION

In this work, learned about plan to accomplish sort out and scrutinizing of overload state of feeder lines by estimating the voltage of each line. In this projected work, a system is designed in such a way that, it will supervise and manage the load continuously and that information is send to user mobile number using IoT technology. Today the world is stirring rapid towards the more active and efficient smart grid technology by exchanging the current time worn technologies. The object of this work is to develop the allocation of power, where hitches resembling burden shedding a typical circumstance.

## REFERENCE

1. Kalpana Patel, Nikhil Bagul, RohitBadodekar, Manish Patil, VinodNikumbh (2019) IOT Based Feeder Protection From Overload and Earth Fault.*International Research Journal of Engineering and Technology (IRJET)*, Vol. 06 No.3.
2. N.Rajeswaran, T.Madhu, and M.Suryakalavathi (2013) Hardware Testable Design of Genetic Algorithm for VLSI Circuits.*Applied Mechanics and Materials*, Vol. 367, pp 245-249, *Trans Tech Publications*.
3. D.RajaReddy(2016) A Novel Approach for Reducing the Power Oscillations in Transmission System by Using Distributed Power Flow Controller.*IJCTA*, Vol.9, No.14, pp.6721-6730.
4. RajaReddy. Duvvuru, B.VenkataPrasanth,V.Ganesh (2018) Performance of Generalized Unified Power Flow Controller in Transmission System.*International journal of renewable energy & technology*, INDERSCINCE, Vol.9, Iss.1-2, pp.108-117.
5. Raja Reddy. Duvvuru, N.Rajeswaran, T.SanjeevaRao (2019) Performance of distributed power flow controller in transmission system based on fuzzy logic controller.*International journal of innovative technology and engineering*, Vol.8, Iss.3,



pp.2039-2043.

6. A. V. Sudhakara Reddy, N. Rajeswaran, D. Raja Reddy (2019) Application of Modified ALO to Economic Load Dispatch for Coal Fired Stations. *International Journal of Recent Technology and Engineering (IJRTE)*, Vol.8 No.2, pp2147-2151.
7. Ch.Narendra Kumar, M.Pradeep, N.Rajeswaran and T.Samraj Lawrence (2019) Sensor Based Smart Monitoring and Controlling System for Cultivation using LabVIEW.*International Journal of Innovative Technology and Exploring Engineering (IJITEE)*, Volume-8 Issue-11, pp.3685-3689.
8. A V Sudhakara Reddy, Balla Shiva Kumar, Ch. Narendra Kumar (2019) A Hybrid Diesel Wind PV Based Energy Generation System.*International Journal of Recent Technology and Engineering (IJRTE)*, Volume-X, Issue-X, pp.1-6.
9. UlliMounika and Ch. Narendra Kumar (2020) Multilevel Inverter Based UPQC for Power Quality.*Journal of Information and Computational Science*, Volume 10 Issue 1, pp. 1206 -1210.
10. D.Raja Reddy, K.Anitha Reddy, Narendra Kumar.Ch, R. Siva Sai Rama Krishna, and Rajesh Reddy. Duvvuru(2020) Design of Transformer Less UPFC based on Multilevel Inverter.*International Journal of Electrical Engineering and Technology*, Vol.11, No.4.