

Survey on Road Traffic Sign Recognition and Vehicle Accident Avoidance System

Nikhil S Rajguru

*PG Student, Department of Computer Engineering
JSPM's Rajashri Shahu College Of Engineering
nikhil.rajguru431@gmail.com*

Abstract

Traffic sign recognition and vehicle accident avoidance system gets a of interest late by huge scale associations, e.g., Apple, Google and Volkswagen and as per the market requirements for smart applications, such as Automatic Driving and Driver Assistance Systems and many more. In this paper, traffic sign recognition and vehicle accident avoidance system is utilized to keep up traffic and maintain a strategic distance from vehicle, caution the occupied drivers, and avoid activities that can lead a vehicle. An on-going programmed sign recognition and detection can support the driver with safety. System propose automated real time system which will capture the traffic sign and show it at driver dashboard with front obstacle exact distance on screen. In this system PiCam is connected with Raspberry Pi and it is used to capture pictures of traffic sings. Screen is utilized to show the system output. This framework is configuration to maintain a strategic distance from vehicle happening on street.

Keywords: –PiCAM, Raspberry Pi, Ultrasonic sensors, Traffic Sign recognition.

1. Introduction

A huge number of traffic sign affirmation structures have been made since the 1980's. First courses of action were focusing on optical based little scale redid hardware in order to keep up a vital good ways from computational multifaceted nature and other contemporary adaptable enrolling related requirements. As demonstrated by the world vehicle road mishap report, India has the top most nation for vehicle road mishap inside the world. Framework should make vehicle driver progressively careful about breaking separation and traffic signs. In this paper, framework propose using raspberry pi and PiCam with ultrasonic sensor, which will caution driver about traffic signs proceeding road and at the same time keep up a vital good ways from front accident using programmed breaking after vehicle enters in breaking separation zone.

2. Background

Visual and symbolic language by side of road is part of traffic signal which are interpreted by driver for smooth and comfortable journey. These signals used are interchangeably around the world, and everywhere they will appear in as same combination, and are termed as ROAD TRAFFIC SIGN. Information provided by them make drivers journey convenient and safe. Earlier Thesis has not explored The Direction Sign which allows the driver about direction as well the distance to the upcoming town. The data that has to be collected or same must have proper roads and traffic signs installed at proper places, they must properly updated and maintained .Earlier for the thesis some authors had meeting with Highway authorities in Sweden and Scotland and it was seen that there is absence of inventory of Traffic signs. The method for detecting the signs, classifying the signs and then logging the signs is the goal provided by automatic capturing of traffic

sign thus developing an accurate database for inventory and maintenance. This step helps human operator for detection of missing and disfigured traffic signs.

3. Related Work

EnisBilgin, et al. [1] work is characterized with speed signs, the main concern is how to cover numbers in picture which show speed which is limited. The speed sign picture has to be captured under various conditions of light variation. The dependency is also on capabilities of Cam used and raspberry Pi. Raspberry Pi performance to control other unit which will be used for system also has effect on system. Necessities and inconvenience which involves base structure with embedded system and to oversee the numbers using pictures taking care of technique which are prone to shape and estimation examination. This is used in various application which are in concern to traffic sign, the paper mainly concerns on light condition variation.

Yi Yang, et al. [2] Yi Yang, et al. [2] Driver accomplice systems (DAS) and free vehicles need consistent traffic sign detections. This is a critical activity appealing despite continuous execution. The picture captured by the cam is the information picture as whole to sort this information and extract traffic sign from whole picture and then crop it and classify it for detection of traffic sign and give affirmation in real time is fast dealing affair. This paper explores the same to give knowledge of variation of speed in brisk of time. The acknowledgment module relies upon traffic sign suggestion, extraction and request dependent which done by Probability model and a HOG. Then gathering of information for convolution neural framework to gathering the recognized signs into their sub classes inside each super class. Acknowledgment for outcomes both German and Chinese boards show that both our methodologies achieve comparable execution with the front line procedures, with essentially improved computational viability.

Priyanka D. et al. [3] Image Planning strategy for self- decision vehicle is portrayed in the work to complete traffic light and sign area recognition. Alerting the driver, using the traffic sign for same and then requesting certain action for same is overall methodology used in this traffic recognition System (TRS). Snappy healthy and ceaseless customized traffic sign revelation and affirmation can support the driver and in a general sense augmentation driving security. Customized affirmation of traffic signs is in like manner critical for a robotized shrewd driving vehicle. Video Data is continuously acquired though the Webcam which is interfaced with RaspberryPi. This is a visual based endeavor i.e., the commitment to the structure is video data which is continually gotten from the web cam is interfaced to the Rasp-berry Pi. Pictures are pre-arranged with a couple of picture taking care of strategies, for instance, In this values of Hue, Saturation and Value (HSV) is taken from space model system which is used for recognizing traffic sign area in whole picture. To recognize the sign area contour algorithm and HSV concealing is applied again. The outcome we get is Region of Interest (ROI) which is than classified for feature recognition like specific geometric shape or color to detect the Traffic Sign.

Wang Canyon et al. [4] Delineate the quick improvement of society and economy; vehicles have ended up being practically one of the invaluable strategies for vehicle for each house- hold. This makes the road traffic condition progressively tangled, and people would like to have a savvy Vision-helped application that outfit drivers with traffic sign information, direct driver exercises, or help vehicle control to ensure road prosperity. As one of the more critical limits, traffic sign disclosure and affirmation, has transformed into a hot research course of researchers at home and abroad. It is generally the use of vehicle cameras to get consistent road pictures, and after that to recognize and perceive the traffic signs experienced all over the place, in this way giving exact information to the driving system. Regardless, the road conditions in the genuine scene are jumbled. After various significant lots of persistent work, examiners have not yet made the affirmation structure sensible, and further research and improvement are so far required. Generally, traffic signage has been perceived and arranged using standard PC vision systems, yet it in like

manner puts aside amazing exertion to physically process noteworthy features of the image. With the headway and progression of science and development, a consistently expanding number of analysts use significant learning advancement to deal with this issue. The rule reason that the significant learning technique is comprehensively recognized is that the model can get acquainted with the significant features in-side the image autonomously from the planning tests, especially for certain cases that don't have the foggiest thought how to design the part extractor, for instance, explanation affirmation, target acknowledgment Wait. In light of the utilization of road traffic sign disclosure and affirmation, this article fixates on the exactness and high capability of distinguishing proof and affirmation.

Meng-Yin Fu et al. [5] Intelligent Transport system wherein the driver uses in vehicle high tech systems to control and be aware of road ahead. This is referred as Advanced Driver Assistance Systems (ADAS). This increases road safety as well reduces the potential accidents or hazards which might be caused due to negligence from driver side to follow the traffic sign rules. This traffic sign recognition is subsystem of ADAS which allows the driver to detect traffic Sign as well drivers around them. Detection, Tracking and classification are the three stages of traffic recognition. The Paper surveys the technology used and development for potential use of Traffic Sign.

Amol Jayant Kale et al. [6] lesser known Road Sign detection and then determination of road sign is probed for Driver Assistance Systems (DAS). In recent times road condition have improved from mud road to tar road and then towards cement road. These improved roads provide with increased lane condition which allows the vehicle to cover long distance in less time but in this speedy journey sometimes the sign boards are neglected by chance from drivers view. The paper explores system which helps the driver to detect these sign board even though when at high speed thus avoiding breaking of rules and in course avoiding accidents. The paper illustrates DAS (Driving assistance System) which allows automatic road-signs recognition, here the system helps driver to increase safety and avoid potential hazard. An approach is stated for the detection and recognition of the road sign in the road and capturing the traffic sign images from a moving vehicle in real time. The system is divided into two parts, primarily detection stage takes place in which whole image are captured then region of interest is detected for Traffic sign and the secondary stage is classification stage that classifies the detected sign into one of the reference signs which are presents in the dataset. For detection, the input image is taken in YCBCR color space, and then shape filtering method is used to determine shape. Artificial neural Network is used to classify the image from referral dataset Experimentation has been done under varying lightening, at different rotations for recognition and detection which proves the system to be robust and efficient.

Zimmermann et al. [7] The system is used for recognition of sign which are circular in shape. The system employs different stages in current Traffic Sign recognition system (TSR) . This is first time that shape based approach is used for to recognize from the content available. SIFT and SURF descriptions are executed for recognizing curve and shapes of content. This increases the performance of system.

\par Saurav Agrawal et al. [8] Introduce an alarming and re- sponse system for moving vehicle using ultrasonic ranging device (URD) which is a combination of a transmitter, a receiver and a single processing device and a microcontroller. The system calculates the minimum safety distance and alarm the driver if distance is low. And if driver doesn't slow down the vehicle then the system will itself apply the brakes and slow the vehicle.

\par V. Kotkar et al. [14] The work provides human behavior as observed by camera in video format. This video is fragmented to form multiple images which are then pre-processed and processed with use of machine learning algorithms to analyze activities of human.

V. Kotkar et al. [15] The abnormal behavior of crowd on road is studied through work immediate running of crowd due to emergency is studied by applying particle filtering to optical flow.

4. PROPOSED SYSTEM

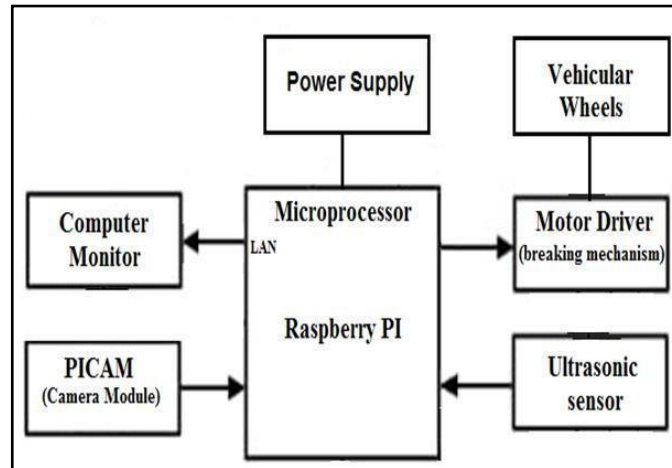

Fig. 1. Proposed System Block Diagram [11][12]

Traffic Sign Recognition: For the purpose of sign recognition the Raspberry Pi Camera is used. The Raspberry Pi Camera Board plugs directly into the CSI connector on the Raspberry Pi. It's able to deliver a crystal clear 5MP resolution image. This camera will capture images of traffic sign and send it to the raspberry pi controller board. Input image is then analyzed using machine learning algorithm which will be able to detect the traffic sign.

Accident Avoidance: For an accident avoidance system, those sensors are used which are able to detect presence of any object or obstacle in front of the vehicle and can be able to measure the distance between two. Therefore to achieve this ultrasonic sensor is used in this project. It works by emitting sound waves at a frequency too high for humans to hear. They then wait for the sound to be reflected back, calculating distance based on the time required. This is similar to how radar measures the time it takes a radio wave to return after hitting an object.

This sensor is used to avoid accident of vehicles. This sensor is placed on the front side of the vehicle which measures distance between other vehicles present in the front. If it detects that the distance is less than the threshold distance the vehicle will automatically stop.

Collision Detection: For an effective collision detection system the sensors must have the high accuracy and quick response time to process the data. This will help in quick collision detection. To do so vibration sensor is used. Sensing crystal is a feature designed by shear mode accelerometer attached between center post and seismic mass under acceleration, the sensing crystals are applied by shear stress due to effect of mass. Piezoelectric material proportion to electrical output is result of this stress. This results in a quick response from the sensor to the controller which leads to a fast and effective collision detection system.

5. CONCLUSION

This survey will be used in a system where PiCAM is recognizing the traffic sign on street and alerting the driver about same. On the off chance that the driver has disregarded the traffic sign, at that point automatic braking system will be actuated by Raspberry Pi

microcontroller. Then again, frame-work will consistently track front vehicle distance utilizing ultrasonic sensor, and breaks will be connected by distance. This will keep away the vehicle from accidents because of sign board carelessness; likewise this will help drivers to keep up safe distance between the vehicles. This will likewise maintain a strategic distance from the accidents happening because of head-on impact. The alarm on dashboard will make driver constantly mindful of the street status.

6. REFERENCES

- [1] D. Priyanka, K. Dharani, C. Anirudh, K. Akshay, M. P. Sunil and S. A. Hariprasad, "Traffic light and sign detection for autonomous land vehicle using Raspberry Pi", International Conference on Inventive Computing and Informatics (ICICI), Coimbatore, pp. 160-164, 2017.
- [2] C. Wang, "Research and Application of Traffic Sign Detection and Recognition Based on Deep Learning", International Conference on Robots Intelligent System (ICRIS), Changsha, pp. 150-152, 2018.
- [3] Meng-Yin Fu, Yuan-Shui Huang, "A Survey Of Traffic Sign Recognition", Proceedings of the 2010 International Conference on Wavelet Analysis and Pattern Recognition, Qingdao, 11-14 July 2010.
- [4] A. J. Kale and R. C. Mahajan, "A road sign detection and the recognition for Driver Assistance Systems", International Conference on Energy Systems and Applications, Pune, pp. 69-74, 2015.
- [5] B. Hoferlin, K. Zimmermann, "Towards reliable traffic sign recognition", IEEE Intelligent Vehicles Symposium, Xi'an, pp. 324-329, 2009.
- [6] S. Agrawal, S. W. Varade, "Collision detection and avoidance system for vehicle", 2nd International Conference on Communication and Electronics Systems (ICCES), Coimbatore, pp. 476-477, 2017.
- [7] Dr.D.Selvathi, P.Pavithra, T.Preethi, "Intelligent Transportation System for Accident Prevention and Detection", International Conference on Intelligent Computing and Control Systems ICICCS 2017.
- [8] S. Sharma, D. Shah, "A Practical Animal Detection and Collision Avoidance System Using Computer Vision Technique", IEEE 2016.
- [9] Traffic Light and Sign Detection for Autonomous Land Vehicle Using Raspberry Pi", IEEE, International Conference on Inventive Computing and Informatics, ICICI 2017.
- [10] "OpenCV Documentation", Web. <http://opencv.org/>, [Accessed November 10th, 2015].
- [11] "Raspberry Pi Foundation", Web. <https://www.raspberrypi.org/> [Accessed October 29th, 2015].
- [12] V. Kotkar, V. Sucharita, "A Comparative Analysis of Machine Learning Based Anomaly Detection Techniques in Video Surveillance", International Conference on Intelligent Sustainable Systems, ICISS 2017.
- [13] V. Kotkar, V. Sucharita, "Particle Filtering Based Optic Flow Computation Model for Crowd Anomaly Detection Using Gaussian Mixture Model", International Journal of Recent Technology and Engineering, IJRTE 2017.