

Real Time Email Alert For Visitor Monitoring System For Surveillance Applications

Sunitha L

Dept. of E&CE

The Oxford College of Engineering ,
Bangalore, Karnataka, India

sunirjbhairava@gmail.com

Dr. Harish H M

Dept. of E&CE

Government College of Engineering
Haveri, Karnataka, India

hmharish@gmail.com

Dr. Yedukondalu U

Dept. of E&CE

SVEC, Tadepalligudem
Andhra Pradesh, India

drykudara@gmail.com

Abstract

The design and implementation of the Visitor Monitoring and Email Alert System (VMES) for Surveillance Applications is the focus of this paper. This framework is primarily focused on achieving a cost-effective VMES in public locations such as railway stations, bus stations, government offices, schools, universities, and other similar locations, with the aim of improving current visitor tracking in log book registers through security personnel and information management practices. In a variety of commercial and non-commercial contexts, people are observed and visitors are welcomed. The number of people entering or leaving stores, the occupancy of office buildings, and the passenger count of commuter trains all provide valuable data to shop keepers and advertisers, police officers, and train operators. In particular, VMES eliminates the need for security personnel to manually record visitor details during visitor registration by using a log book register. The VMES allows for the retrieval of visitor information from the device, which is then used to verify their identification as they reach campus premises. According to this report, the percentage of improvement achieved by using VMES is 30 to 60% higher than that achieved by manual recording, while the percentage of improvement achieved by using VMES for a current visitor scheme is 80 to 90%. This study's additional analysis includes the use of email alert authentication methods such as images and video clips to replace the existing manual recording process with a faster reading speed, as well as a notification mechanism to notify the visitor's arrival to the visiting person.

Keywords: Raspberry Pi, Monitoring, Visitor, Pi Camera, Sensor

1. Introduction

Visitor Monitoring and email alert system, typically refer as a structure to keep tracking visitor's activities in organization or public building. It can provide necessary output and information to the users and record the incoming visitors within the shortest time and also keeps the count of the visitors. Nevertheless, VMES also capable to make more efficient way of monitoring process and provide an authentic and integrated data of the visitors. [1] Generally, there are many government buildings or public premises are still using the conventional paper log or guest book to record the access of the visitors. This manual method consumes longer time when the number of visitors is exceeded the limit. Meanwhile, an increasing number of visitors indicates that the security issues should be concern in the government buildings or public premises. [2] This is mainly because the operators are lack of time to verify the identification of each visitor when they are tons of guest entering the building. [3] Moreover, paper log is inadequate to offer greater

traceability in which cannot be archived or efficiently retrieved after several years. [4] Due to above circumstances, VMES contribute a good solution to solve the problems exist in the conventional method. To enter the building is an easy way and to identify and record the visitor's information. [5] This authentication system also helps the security officer to determine whether the visitors are giving the right to enter the building. [6] In this paper, an automated VMES is designed and developed to assure the simplification of process before entering the premises.

4. Literature Survey

4.1 A People Counting Technology

People counting are a widely studied and commercially exploited subject. This section briefly reviews the typical technologies used for people counting. *B Video Cameras* In the authors describe an approach to people counting (and localization) using multiple video cameras. The focus lies on extracting the size and moving patterns of individuals passing. By means of motion histograms based on frame-differenced images, the histograms classify detected movements. Probabilistic correlation is applied to determine a people count. The results of multiple cameras are joined in order to form a movement vector for each individual recognized. In contrast, proposes a solution based on a single ceiling-mounted camera, which identifies people by background extraction of the camera image. A non-background “blob” is recognized, and its size is estimated and compared to previously established bounds of people's pixel dimensions. A people count is derived from the results of this analysis. The system reaches a claimed accuracy of 98.5%. The major disadvantage of a camera-based system is that it requires an ambient light source and relatively powerful computer resources to perform image processing.

4.2 Ultrasonic Sensors

The authors of introduce a system employing ultrasonic sensors. Per each observed area a three-node sensor cluster is established, whereby each sensor node mounts an ultrasonic sensor. Multiple clusters are joined to cover a wider area. Nodes in each cluster communicate sensor readings by an RF link to the cluster's coordinator node. The latter contributes its own sensor measurements. By means of a distributed algorithm, nodes decide on whether to count a detected person. The sensor nodes require clock synchronization at the millisecond level in order to correlate the data exchanged. Despite the availability of clock synchronization protocols this imposes a disadvantage to this approach. The system achieves an overall counting accuracy of 90% using a probabilistic estimate of the total count, despite individual clusters achieving only around 50-70% accuracy.

4.3 Infrared Sensor

IR arrays combine a matrix of IR sensors to form array detectors. As the name suggests the sensor signals are provided as a matrix, where each element of the matrix corresponds to one IR sensor. Pattern recognition algorithms are able to detect people moving across the sensor's view at a claimed accuracy of 95%. This holds true even if two pedestrian's paths cross, or people walk in parallel. IR arrays provide a cost-effective solution and also operate without any ambient light source. IR arrays are widely used in commercial systems.

4.4 Infrared Motion Sensors

In people counting system based on PIR motion detectors, for each passage monitored, three PIR sensors are installed at a distance of 0.8m. The sensors are connected to a coordinator by a wireless RF link. Sensors detect motion events and send these data to the coordinator. The coordinator infers a people count from correlating the number, phase and time difference of peaks found in the signal. The system achieves a rate of 100% to detect the direction of movement, and accurately detects 89% of the number of people passing. PIR sensors provide an alternative to IR sensor arrays, however the cost and effort of employing multiple sensor nodes for each entry/exit point is a cost-side disadvantage. The goal of this thesis is to develop a system based on just one PIR sensor and one sensor node per each observed entry/exit point. Sensor Fusion Results of a building occupancy estimation system applying different types of sensors is found in [6]. The system consists of camera, CO₂ and PIR sensors. It uses a Hidden Markovian Model (HMM) based on an Extended Kalman Filter (EKF) in order to derive building occupancy. The approach integrates historical data and current sensor readings to estimate the true state of the system, adjusting for sensor noise (false observations) and stochastic processes, e.g. uncertain people movement patterns.

4.5 Open CV Simple Motion Detection

This project is a program use OpenCV to detect motion and save pictures. Publish by Cédric Verstraeten on website: www.cedricve.me on February 5th, 2013. This program introduction an algorithm use OpenCV to compare different between two images. The algorithm is supposed have 2 images, the images are a taken with some delay c between them. If we compare every pixel of the 2 images and they're all the same, we could say the 2 images are same. But if they don't, we could say there something happen during the delay time c . Maybe someone place an object in front of the camera or passing.

4.6 Motion Detection and Object Tracking in Image Sequences

Artificial intelligence is an important topic of the current computer science research. In order to be able to act intelligently a machine should be aware of its environment. The visual information is essential for humans. Therefore, among many different possible sensors, the cameras seem very important. Automatically analyzing images and image sequences is the area of research usually called 'computer vision'. This thesis is related to the broad subject of automatic extraction and analysis of useful information about the world from image sequences. The focus in this thesis is on a number of basic operations that are important for many computer vision tasks. These basic steps are analyzed and improvements are proposed.

4.7 Motion Detection and Object Tracking in Image Sequences

It had introduction algorithm of how to detect motion using image. The algorithm is a static camera observing a spot is a common case of a monitor system [12, 30, 8,23]. Detecting invade objects is a necessary step in analyzing the spot. A usually applicable hypothesis is that the images of the spot without the invade objects exhibit some regular behavior that can be well depict by a statistical model. If we have a statistical model of the spot, an invade object can be

detected by spotting the parts of the image that don't fit the model. This process is usually known as "background subtraction".

Usually a simple bottom-up way is applied and the spot model has a probability density function for each pixel divided. A pixel from a new image is considered to be a background pixel if its new value is well depicted by its density function. For example for a static spot the simplest model could be just an image of the spot without the invade objects. The next step would be, for example, to forecast appropriate values for the change of the pixel intensity levels from the image since the change can vary from pixel to pixel. However, pixel values often have complex layout and more elaborate models are needed. In this project, consider two popular models: the parametric Gaussian mixture and the non-parametric k nearest neighbors (k-NN) estimate. The spot could change from time to time (suddenly or slow illumination changes, static objects deleted etc.). The model should be frequently updated to incarnate the most current situation. The main problem for the background subtraction algorithms is how to automatically and efficiently update the model. This project analyzes the results from the literature and extracts some basic principles. Based on the extracted principles we recommend, analyze and compare two efficient algorithms for the two models: Gaussian mixture and k-NN estimate. The Gaussian mixture density function is a popular flexible probabilistic model. A Gaussian mixture having a fixed number of components is constantly updated using a set of heuristic equations. Based on the results from the previous chapter of this thesis and some additional approximations we propose a set of theoretically supported but still very simple equations for updating the parameters of the Gaussian mixture. The important improvement compared to the previous approaches is that at almost no additional cost also the number of components of the mixture is constantly adapted for each pixel. By choosing the number of components for each pixel in an on-line procedure, the algorithm can automatically fully adapt to the scene. We propose an efficient algorithm based on the more appropriate nonparametric k-NN based model. The both algorithms have similar parameters with a clear meaning and that are easy to set. This project also suggests some typical values for the parameters that work for most of the situations. Finally, we analyze and compare the two proposed algorithms.

5. Design Methodology

5.1 System Architecture

Before starting to develop and design the VMES, it is necessary to identify the system requirement for the items that used in this project. The system requirement of the VMES is the configuration, functional and data requirement as well as the quality constraint of the processor. The objective of system requirement is to ensure the VMES is running smoothly and efficiently so that it could make the monitoring process faster and easier.

In this paper, to count the number of people entering from the door, Raspberry Pi board has been used which is a SBC, on which we interfaced a Picamera. Picamera is used for capturing the images of the people. The Raspberry Pi board is connected to the monitor (Display) through HDMI port, for getting the results. The monitor shows the number of people captured by Picamera. The number of face detected is displayed on the counter. OpenCV is a library which is used for interfacing the camera to the board.

In this, a Pi camera is used to capture the images of visitors, when a sensor detects a movement of a persons. A DC motor is used as a gate. Whenever anyone wants to enter in the place then he/she needs to push the button. After pushing the button, Raspberry Pi sends command to Pi Camera to click the picture and save it. After it, the gate is opened for a while and then gets closed again. The buzzer is used to generate sound when sensor senses the movement of persons and LED is ON, and system is ready for operation.

Here the images of visitors are saved in Raspberry Pi with the name which itself contains the time and date of entry. Means there is no need to save date and time separately at some other place as we have assigned the time and date as the name of the captured image.

Requirements and specifications.

Components required

- Raspberry Pi
- Pi camera
- PIR Sensor
- 16x2 LCD
- DC Motor
- Buzzer
- LED
- Power supply

Description:

a Raspberry Pi Board :The Raspberry Pi Camera Board figure 1 is a custom designed add-on module for Raspberry Pi hardware. It attaches to Raspberry Pi hardware through a custom CSI interface. The sensor has 5 megapixel native resolutions in still capture mode. In video mode it supports capture resolutions up to 1080p at 30 frames per second. The camera module is light weight and small making it an ideal choice for mobile projects.

In this example figure 2 you will learn how to create a camera board object to connect to the Raspberry Pi Camera Board, capture images from the camera and process them in Python programming. Raspberry Pi Model B has 512Mb RAM, 2 USB ports and an Ethernet port. It has a Broadcom BCM2835 system on a chip which includes an ARM1176JZF-S 700 MHz processor, Video Core IV GPU, and an SD card. It has a fast 3D core accessed using the supplied OpenGL ES2.0 and OpenVG libraries. This board is the central module of the whole embedded image capturing and processing system as given in figure 3.1. Its main parts include: main processing chip, memory, power supply HDMI Out, Ethernet port, USB ports and abundant global interfaces.

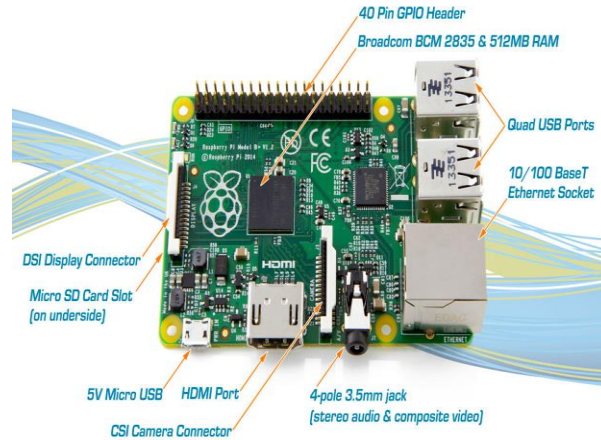

Figure 1: Raspberry Pi Module

The Raspberry Pi 2 delivers 6 times the processing capacity of previous models. This second generation Raspberry Pi has an upgraded Broadcom BCM2836 processor, which is a powerful ARM Cortex-A7 based quad-core processor that runs at 900MHz. The board also features an increase in memory capacity to 1Gbyte.

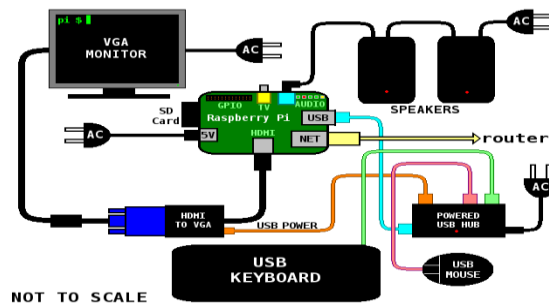

Figure 2: Circuit diagram of camera interfacing with Raspberry pi.

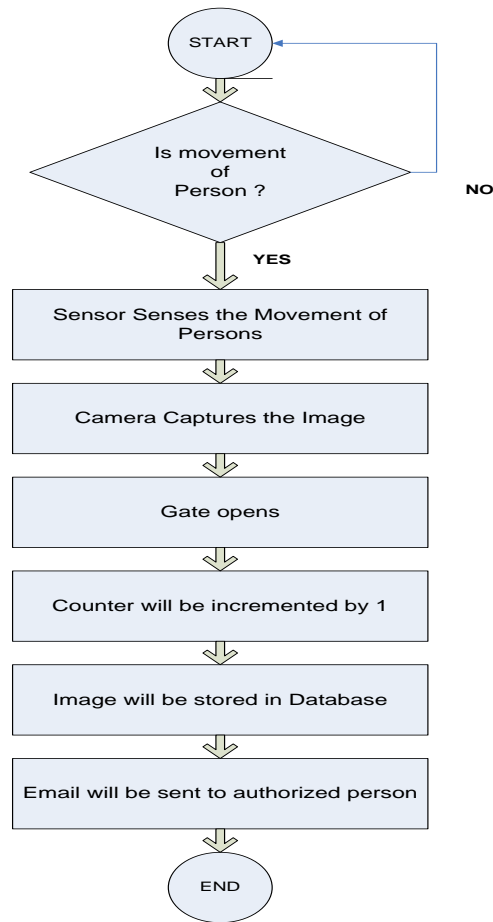

Figure 3: Flow Chart

6. Implementation Diagram

This time we are here with our next interesting part which is Visitors Monitoring System with Image capture functionality. Here we are interfacing Pi camera with Raspberry Pi to capture the image of every visitor which has entered through the Gate or door. In this paper, whenever any person is arrived at the Gate, PIR sensor sense the movement of the visitors, automatically opens the Gate, and at the same time, his/her image will be captured and saved in the system with the date and time of the entry. An Email alert will be sent to authorize person/s email ID which is registered with this system. This can be very useful for security and surveillance purpose which is presented in figure 4.

This system is very useful in offices or factories where visitor entry record is maintained for visitors and attendance record is maintained for employees. This Monitoring system will digitize and automate the whole visitor entries and attendances, and there will be no need to maintain them manually. This system automatically works for very visitor.

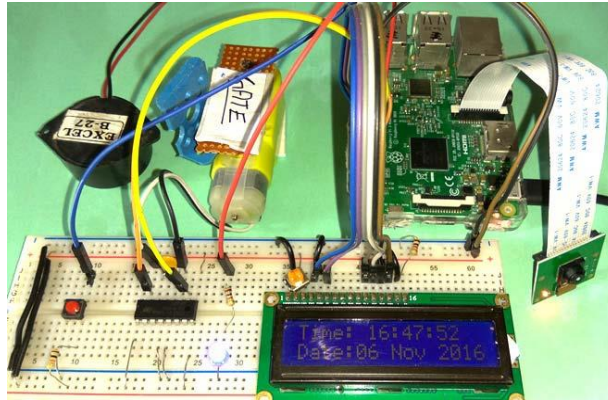

Figure 4: System Setup with Hardware

Working Explanation

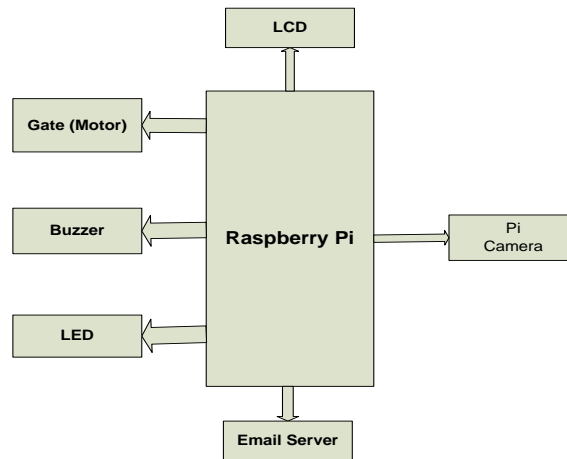

Figure 5: Block diagram of the proposed system

Here the pictures of visitors are saved in Raspberry Pi with the name which itself contains the time and date of entry. Means there is no need to save date and time separately at some other place as we have assigned the time and date as the name of the captured picture.

Circuit Explanation

Circuit of this Raspberry Pi Visitor monitoring System is very simple. Here a Liquid Crystal Display (LCD) is used for displaying Time/Date of visitor entry and some other messages. LCD is connected to Raspberry Pi in 4-bit mode. Pins of LCD namely RS, EN, D4, D5, D6, and D7 are connected to Raspberry Pi GPIO pin number 18, 23, 24, 16, 20 and 21. Pi camera module in figure 7 is connected at camera slot of the Raspberry Pi. A buzzer is connected to GPIO pin 26 of Raspberry Pi for indication purpose. LED is connected to GPIO pin 5 through a 1k resistor and a PIR sensor is connected to GPIO pin 19 with respect to ground, to trigger the camera and open the Gate. DC motor (as Gate) is connected with Raspberry Pi GPIO pin 17 and 27 through Motor Driver IC (L293D). Rest of connections is shown in circuit diagram.

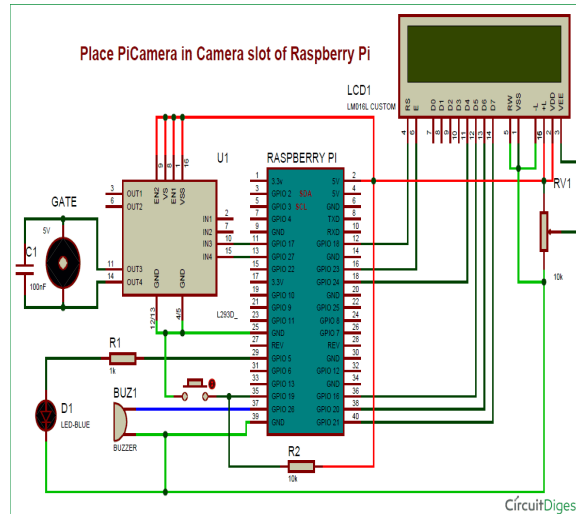

Figure 6: Circuit Connections

To connect the Pi Camera, insert the Ribbon cable of Pi Camera into camera slot, slightly pull up the tabs of the connector at RPi board and insert the Ribbon cable into the slot, then gently push down the tabs again to fix the ribbon cable.

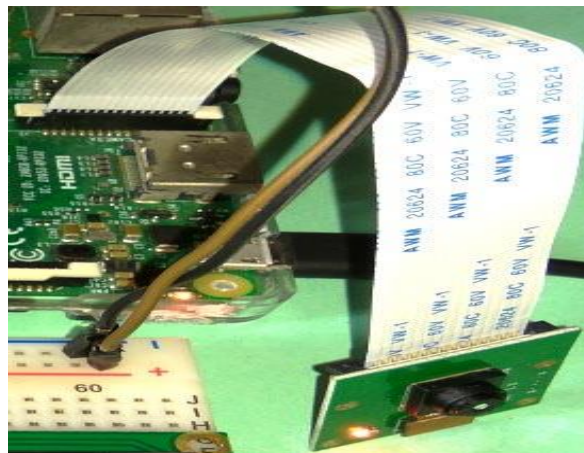

Figure 7: Pi Camera Module

7. Results

While designing PCB for relay circuitry, LED and relay were not working simultaneously. Relays are used as a switch, which is used to reset and give pulse for counter. So the LED was removed and circuitry containing relays, connectors, resistors, transistors, diodes was designed. Counter was added so that number of face detected could be visible in numbers. Regarding program some algorithms were added, for proper face detection

Work Flow in Snaps

Step 1

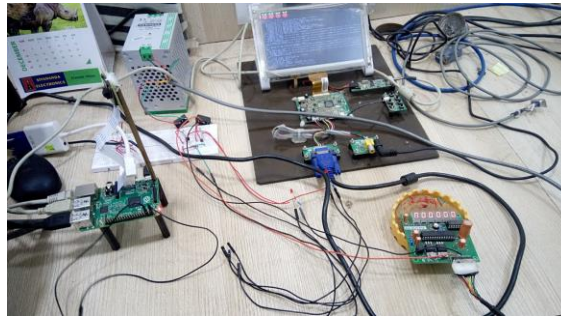

Figure 8: Initialization of Raspberry Pi and Counter

In this paper counter circuitry has been used for counting the images figure 8 detected by the Picamera and also shows the count of stored images.

The counter can count upto range 000000 to 999999.

Step 2 (Option 1: Capture image from camera and sending email)

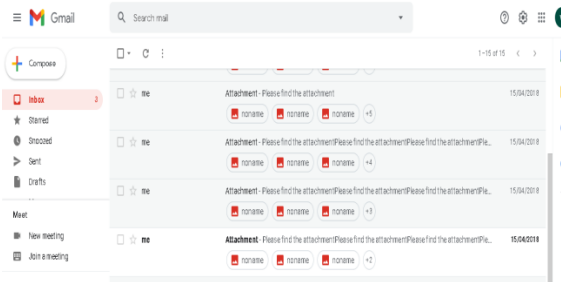

Figure 9: Capture and sending image through email to authorized persons

Conclusion

This current paper is focused with an objective of design and development a VMES that is affordable for the government buildings or public premises. The proposed VMES has a lower average cost than other current VMS on the market in this project. According to the findings of the study, the proposed VMES will reduce the time it takes to track visitors to government buildings or public places. Furthermore, since the VMES could produce an aggregate report immediately, it massively decreased the security officer's workload. In reality, despite being over budget for the project and approaching the submission deadline, there is more that can be improved. The lack of authentication tools to authenticate the visitor's identity in the VMES built in this project. This can allow a visitor with criminal intent to steal information from others to gain access to government buildings or public areas. As a result, a biometric fingerprint device may be used to improve the reliability of the visitor monitoring system. As soon as a guest approaches the entrance, an email message will be sent. Furthermore, facial recognition should be used on this guest tracking device because it has a higher degree of security than other biometric methods. To do this, a higher-quality camera could be used to capture more pixels of the visitor's face image. Moreover, the processing speed can be increased to speed up the

monitoring process. For a faster reading rate, the time it takes to retrieve information may be reduced from 30 seconds to less than a minute. Last but not least, this project has the potential to improve in a variety of areas since it can still be updated and modified to meet the needs of the users. As a result, it is clear that there are many ways to improve this project on a daily basis that are not limited to a single aspect.

References

- [1] K. Terada, D. Yoshida, S. Oe, and J. Yamaguchi, A method of counting the passing people by using the stereo images, International conference on image processing, 0-7803-5467-2, 1999
- [2] Haritaoglu and M. Flickner, Detection and tracking of shopping groups in stores, Proceedings of the 2001 IEEE Computer Society Conference on Computer Vision and Pattern Recognition , 0-7695- 1272-0,2001.
- [3] Gary Conrad and Richard Johnson baugh, A real-time people counter, Proceedings of the 1994 ACM symposium on Applied computing, 0-89791-647-6, 1994[ROS94] : M. Rossi and A. Bozzoli, Tracking and Counting Moving People, IEEE Proc. of Int. Conf. Image Processing, , 1994.
- [4]. Roy Ellwood. (2011). Build A Home Webserver
- [5]. Price, Peter.(2011). "Can a £15 computer solve the programming gap?". BBC Click.
- [6]. Moorhead, Joanna.(2012). "Raspberry Pi device will reboot computing in schools". The Guardian (London).
- [7]. Gary Bradski. (2008). Learning OpenCV: Computer Vision with the OpenCV Library. ISBN-13:978-059616130
- [8]. Daniel LellisBaggio. (2012). Mastering OpenCV with Practical Computer Vision Projects. ISBN-13: 978-184517829
- [9] Carlo Tomasi Takeo Kanad Detection and Tracking of Point Feature Technical Report CMU-CS-91-1350
- [10] Nicolai Petkov· Easwar Subramanian Motion detection, noise reduction, texture suppression, and contour enhancement by spatiotemporal Gabor filters with surround inhibition Publishedonline:25October2007
- [11]Motion_Detection_Programming_Guide_V1.1 GM8126
- [12] Price, Peter "Can a £15 computer solve the programming gap?". BBC Click. 2 July 2011.
- [13] "David Braben on Raspberry Pi". Edge. 25 November 2011. 8 December 2011.
- [14] Moorhead, Joanna "Raspberry Pi device will 'reboot computing in schools'". The Guardian (London). 20 January 2012.
- [15] "What is web server?". Web developers notes. 23 November 2013.
- [16] "Distributed Application Architecture". Sun Microsystem.16 July 200951.
- [17] "Interview with Eben Upton – Raspberry Pi Founder". International Business Times. 19 March 2012.
- [18] "Linux news showing the first release of Debian Squeeze for Raspberry running on QEMU". Linuxnewshare.com. 16 July 20012
- [19] "Raspberry Pi maker says code for ARM chip is now open source". ArsTechnica. 3 November 2012.
- [20] Shead, Sam. "Raspberry Pi delivery delays leave buyers hungry (and angry)". ZDNet. 18 October 2012.
- [21] Vallance, Chris. "Raspberry Pi bids for success with classroom coders". BBC News. 29 February 2012.
- [22] Steve Silva(2008). Web Server Administration.ISBN-13: 978-1423903239
- [23] Alan Winston(2002). OpenVMS with Apache, WASD, and OSU: The Nonstop Webserver (HP Technologies). ISBN-13: 978-1555582647