

## Wireless Networks

R. RAJ KUMAR

*B.C.A., M.C.A., PGDBM. Trainer, Software Training, Datapro Computers Pvt Ltd,  
Hyderabad, India*

*rajkumarreddy123@gmail.com*

### Abstract:

*In the present scenario, wireless communication plays a significant role all over the world. Wireless communication is a process of transmitting data between at least two focuses that are normally not associated with wires. Separations could be short, for example, a couple of meters for air-conditioner remote control, or even miles of distance for radio communication. It includes various types of fixed systems, mobiles, cellular telephones, personal digital assistants, portable two-way radios, Global Positioning System units, wireless keyboards & mouse, Bluetooth headsets, radio receivers and wireless networks etc. In this article the author intends to explain about the wireless networks, contrast between wired and wireless network, types of wireless networks, comparison of wireless network types, and benefits of wireless network.*

**Keywords-**Wireless networks, WPan, WLan, WMan, and WWan

### Objective of the Study

- 1.To study the Wireless Networks.
- 2.To study the differences between wired and wireless network.
- 3.To study the types of wireless networks and their comparison.
- 4.To study the benefits of wireless network.

### Research Methodology

The study depends on secondary information gathered through different Books, magazines, Journals, papers, Internet sites and research studies.

## 1. INTRODUCTION

In a data communication, the transmission channel is the physical way among transmitter and beneficiary. Communication media can be categorized into two types as follows. Correspondence in both the types is as radio waves. <sup>[2]</sup>

1.1 Guided Media: The radio waves are directed along a strong medium, for example, twisted pair and so forth.

1.2 Unguided Media: The aerosphere and external space are the instances, which provide with methods for communicating radio wave signals anyhow don't manage them; this kind of correspondence is generally refer to as wireless network.

For unguided media, transmission and gathering are accomplished by methods for an antenna. For transmission, the antenna transmits electromagnetic energy into the channel (normally air), and for gathering, the reception apparatus gets electromagnetic waves from the encompassing medium. There are fundamentally two sorts of designs for wireless transmission: directional and omnidirectional. For the directional design, the channel radio waves puts out an engaged electromagnetic beam; the sending and getting receiving antennas should in this way be deliberately adjusted. In the omnidirectional case, the communicated signal spreads out every which way and can be gotten by numerous radio waves. <sup>[2]</sup>

According to Electronic Sector Skill Council defined “Wireless Network is also called as Radio Frequency, which uses radio waves to get to the Internet from any versatile or remote gadget. A

client can do all that they could from a typical PC, for example, organizing PCs, sharing documents, email, access printers, and different assignments without being associated by difficult links." [3]

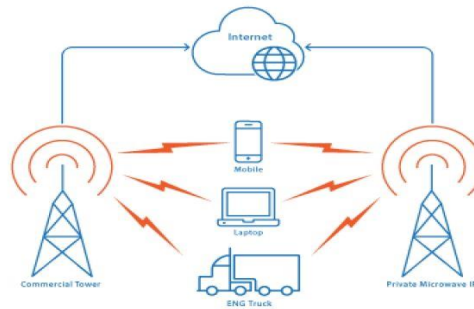

Fig 1: Wireless Network [8]

1.0 CONTRAST BETWEEN WIRED & WIRELESS NETWORK[1]

Table1: Contrast between wired and wireless network

Wired Network	Wireless Network
It is typically stationary	Its correspondence implies portability
Wire frameworks send information through cables utilized unshielded twisted pair and Shielded twisted pair.	Wireless frameworks send information through radio waves
Wired frameworks are inalienably secure on the grounds that information isn't communicated over the air.	Wireless frameworks are less secure as contrast with wired correspondence since they are available to listening the air for signals.
In wired correspondence obstruction is very less.	Obstruction is more when contrasted with wired correspondence.
Wired Connection offers more predominant execution.	Wireless correspondence has less performance as contrasted with wired association.

2.0 TYPES OF WIRELESS NETWORKS

2.1 WPAN

According to Steve Rackley, 2007 defined "Personal area network is an interrelationship of gadgets for individual use inside the working space of an individual typically in the scope of 1–10 meters. Wireless PANs plan to accomplish this interrelationship and give more prominent adaptability, portability and opportunity from the problem of finding the correct link." They center around the particular data and availability needs of the individual synchronizing information from a PC to a portable gadget, trading information between compact gadgets and giving Internet network to convenient gadgets. The sort of gadgets that were envisaged as taking an interest in the PANs was the pervasive cell phone and afterward progressively normal Bluetooth gadgets, for example, wireless mouse, remote keyboards, sound headsets, printers may interface with PDAs, and WIFI. [4]

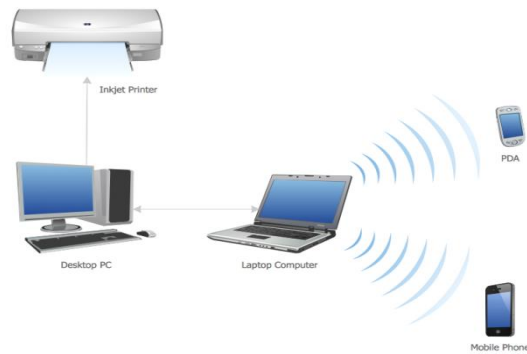

**Fig 2 Wireless Personal Area Network** <sup>[9]</sup>

## 2.2 WLAN

According to Barry Lewis and Peter T. Davis, 2004 defined A Wireless Local Area Network is homogenous to the wired neighborhood you utilize every day at the workplace or even in your home. It gets you associated with the workplace with your PC or tablet PC permitting you to roam around grinding away while staying associated and permit sharing of assets without any connected wire. This type of network grows past the zone of our work areas and moves us to additional separations. Separations of up to 500 feet are conceivable with no obstruction. This can be particularly helpful for little and medium organizations, for example, a school, PC laboratory, lodgings or hotels and place of business and so on. <sup>[5]</sup>



**Fig 3 Wireless Local Area Network** <sup>[10]</sup>

## 2.3 WMAN

The Wireless Metropolitan Area Networks are additionally once in a while alluded to as Wi-Max and Wireless Man. WMAN offers remote admittance to structures using outside antenna apparatus getting to focal base stations. WLAN is incredible for one structure or a couple of floors, yet on the off chance that you are an enormous association with topographically separate structures over a city, you may require the all-inclusive separation that WMAN offers. Associating networks situated in discrete structures prompts significant advantages, for example, clients getting to important information residing in focal assets crossing huge open spaces (office buildings and colleges, for instance). An organization network can extend from one room, to one structure, to numerous structures, within a city. (Barry Lewis and Peter T. Davis, 2004). <sup>[5]</sup>

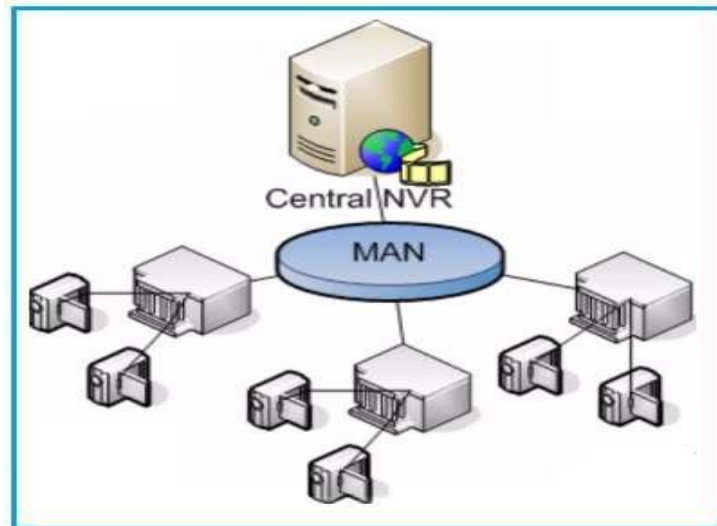

**Fig 4 Wireless Metropolitan Area Network** <sup>[11]</sup>

**2.4 WWAN**

A wireless wide area network spans an enormous zone. Frequently used to depict a cell phone communication network wherein the client is toward one side and the antenna must be at the opposite end.<sup>[3]</sup> The Cyberspace is the biggest WAN, traversing the Earth. A WAN is a correspondence network comprised of PCs that are non-local to each other, trading information over a wide region or significant stretch. A WAN is a geologically scattered group of LANs. WANs spread urban communities, nations, landmasses and the entire world.<sup>[6]</sup>

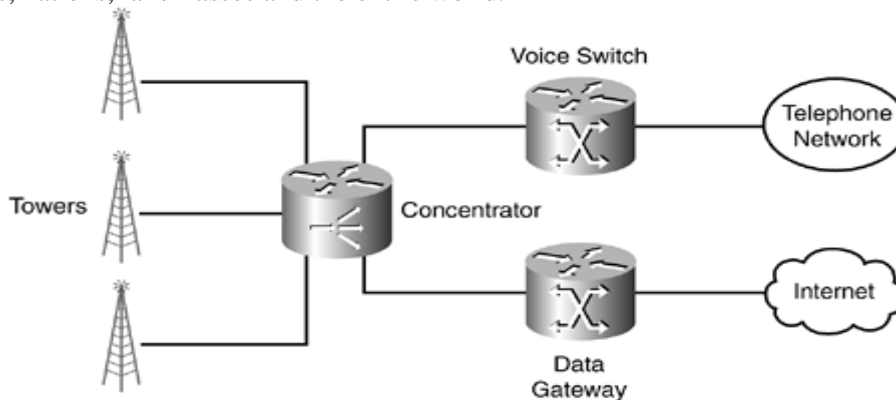

**Fig 5 Wireless Wide Area Network** <sup>[12]</sup>

**3.0 COMPARISON OF WIRELESS NETWORK TYPES**<sup>[13]</sup>

**Table 2 Differentiation of network types**

Network Type	Range	Performance	Applications
WPAN	Reach across of an individual	Moderate	Cable swap for peripherals
WLAN	Across a building or campus	High	Wireless augmentation of wired network
WMAN	Across the metro city	High	Wireless between network connectivity
WWAN	WANs spread urban communities, nations, landmasses and the entire world.	Low	Mobile admittance to the Internet from open air areas

**4.0 BENEFITS OF WIRELESS NETWORKS**<sup>[7]</sup>

**4.1 Mobility**

The clearest benefit of wireless fidelity is portability. Clients move, yet information is normally put away halfway, for example, mobile clients associates through antennas. Empowering clients to get to information while they are moving can prompt huge efficiency gains.

**4.2 Flexibility**

No link signifies no recabling. Wireless organizations authorize clients to promptly frame indistinguishable, miniature collection of networks for a gathering, and wireless fidelity makes move in the middle of workplace and workstations span.

**4.3 Ease and speed of deployment**

Indeed, even in present days, business or firm's contraction for linkage initiation using cables can be costly and tedious. Wireless organizations commonly have a great deal of adjustability that can transform into fast arrangement.

**4.4 Scalability**

A wireless organization operates different base stations to hookup clients to a present organization. The framework boundary of a wireless organization, anyway subjectively a related whatever you are bond 1 consumer or 1,000,000 consumers. To provide help in a specified zone, you require antennas and base stations build up.

**4.5 Reduced Cost**

At times, expenditure can be decreased by applying wireless networking. Subsequently, highlight point of wireless correspondences are ways to lower expenditure than tariff limit from the telephone organization.

**4.6 Security**

When that framework is constructed, notwithstanding, add up a client to a wireless organization is commonly a thing of permission or confirmation.

**CONCLUSION**

A study is given about the wireless networks. This paper analyzes types of wireless networks, and their comparison, which can serve to select network in different situation depending on the requirement of customer. The requirement for remote innovation has developed hugely over the most recent years. Remote innovation unites the two greatest ventures together: the Internet with the Mobile innovation. In future, a great deal of work should be possible to create new innovations to improve the exhibition with respect to surmising, effectiveness, security and different issues identified with both systems.

**Acknowledgment**

I am sincerely thankful to International E-Conference on Advanced Computing Technologies organized by Bhavan's Vivekananda College, Sainikpuri for providing me with the opportunity to write a research paper on the topic "Wireless Networks". I am also thankful to my colleagues for the constant encouragement. Then, I would like to thank my family members and friends for their kind cooperation in completion of the research paper.

**REFERENCES****Journal Papers:**

1. Sachin Gupta, A Comparative Analysis of wired and wireless network architecture, International Journal of Emerging trends in Research, Volume 1, Issue 1, 2016, Pg. No. 05-11.

**Books:**

2. Wireless Communications and Networks, Second Edition, William Stallings, ISBN No. 0-23-292635-4, Pg. No. 31.
3. NSDC-FTCP-Courseware-21-May-2016, Field Technician Computer & Peripherals, Participant Handbook, First Edition, Electronic Sector Skills Council of India (ESSCI), Pg. No. 379-380.

4. [Online Book] Wireless Networking Technology, Steve Rackley, 2007, ISBN No. 0750667885, Pg No. 251 - 253
5. [Online Book] Wireless Networks for Dummies, Barry Lewis and Peter T. Davis, 2004, ISBN No. 0764575252 Pg No 14 – 17
6. [Online Book] Wireless Network, DCAP311\_DCAP607\_WIRELESS\_NETWORKS, Lovely Professional University, Page No. 165-166
7. [Online Book] 802.11 Wireless Networks: The Definitive Guide, Matthew Gast, ISBN No. 0-596-00183-5, Pg. No. 6.

**Websites:**

[8] <https://www.liveu.tv/solutions/57-solutions/ bespoke-wireless>

[9] <https://www.conceptdraw.com/How-To-Guide/picture/personal-area-network.png>

[10] <https://techterms.com/definition/wlan>

[11] <https://www.rfwireless-world.com/Terminology/Advantages-and-disadvantages-of-MAN.html>

[12] <http://etutorials.org/Networking/wn/Chapter+7.+Wireless+WANs+Networks+for+Worldwide+Connections/Wireless+WAN+Systems/>

[13] <https://www.computernetworkingnotes.com/ccna-study-guide/types-of-wireless-network-explained-with-standards.html>

[14] <https://www.engpaper.com/wireless.htm>

[15] <https://hpbn.co/introduction-to-wireless-networks/>