

Electric Power Generation from Photo-voltaic Renewable Energy System

Mohammad Junaid Khan¹, Pushparaj²

¹*Department of Electrical and Electronics Engineering, Mewat Engineering College Nuh, Haryana, India*

²*Department of Electronics and Communication Engineering, National Institute of Technical Teachers' Training and Research, Chandigarh, India*

Abstract

Photovoltaic (PV) solar panel is one of the most popular devices for transforming solar energy into electrical energy. This is basically a main transducer. The PV system has several different characteristics, it will change its characteristics by adjusting the conditions of the atmosphere such as radiation and temperature, because the PV system does not have full power because of this situation. Therefore, in this control method we can figure out the maximum power using boost converter and fixed duty cycle, as the output power of the PV system is more fluctuating, therefore regulating and raising the output power and raising the PV system performance and monitoring the maximum power level.

Keywords: *PV, Boost Converter, Resistive Load and control system.*

1. Introduction

Throughout modern industries, renewable energy sources have been used for the last three decades and can be easily regulated using different equipment. Where, there is no public infrastructure. Solar PV is the tool that converts solar energy into electric power. Solar PV is one of the fastest growing energy technologies, with an annual average growth of about 40 percent over the past decade [1-5]. In 2009, the overall installed capacity is 2.5GW, which is an improvement of more than 50 percent compared to the previous year and has resulted in an overall PV capacity of 7.8GW worldwide [6–10]. PV system's rising pace is much faster than other power plants, due to their products and benefits.

The proposed PV system includes the following equipment and components, such as PV collection, boost converter, fixed duty cycle as control system, and resistive load. The boost converter duty cycle is calculated using fixed value process. Fig. 1 displays a block diagram of the proposed renewable PV energy framework.

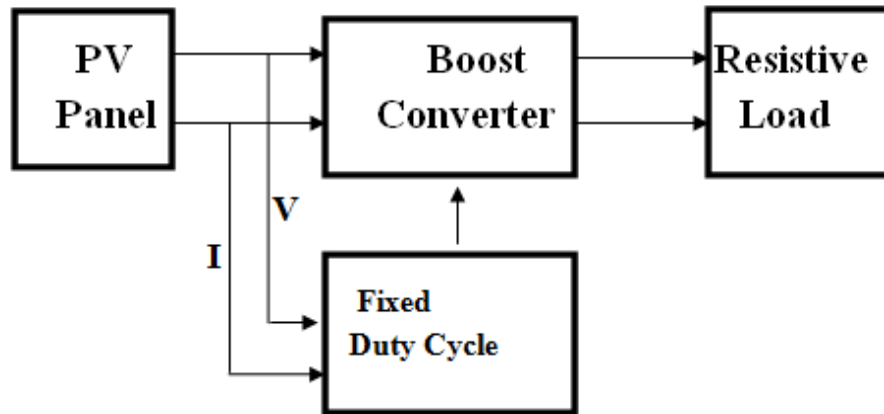

Fig.1. Block Diagram of Proposed PV Renewable Energy System

The main function of the control system is to increase electrical input from the PV panel, with constant output power. Using fixed duty process, high efficiency will ensure that the dc power is converted to the load. Using boost converter, we can monitor the maximum power of the PV system, and using MATLAB, PV system is implemented based on simulation performance.

2. Boost Converter

One of the simplest types of switch-mode converters is a boost converter. As the name suggests, an input voltage is required, and it boosts or increases it. All it consists of is an inductor, a semiconductor switch (these days it's a MOSFET because these days we can get really good ones), a diode and a condenser. Also required is a source of a periodic square wave. This can be something as basic as a 555 timer or even a dedicated SMPS IC like the popular MC34063A IC. Fig. 2 shows the boost converter.

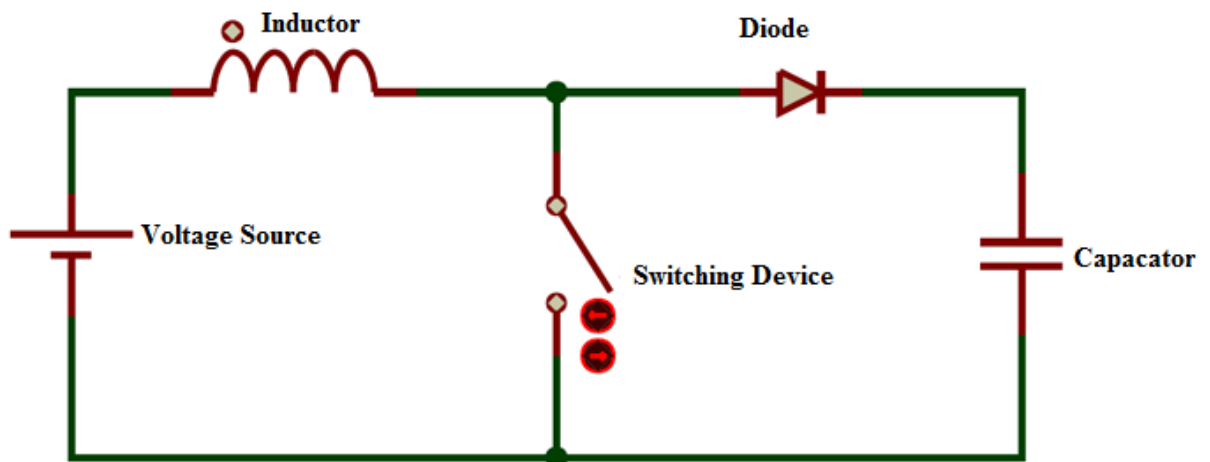

Fig. 2. Circuit Diagram of Boost Converter

As we can see, it just takes a couple of parts to make a boost converter. This is less bulky than an inductor or an AC transformer. They're so easy because they were originally designed to power the electronics systems on aircraft in the 1960s. Such converters were a requirement that they be as lightweight and as effective as possible. The biggest benefit given by boost converters is their high

performance – some can even go up to 99%. In other words, 99 per cent of the energy input is transformed to usable energy production, just 1 per cent is lost.

3. Component used in Proposed System

Main components for electric power generation from PV system are discussed below:

3.1 Oscillator

We can't keep the MOSFET output switch on forever, there is no perfect inductor-they have saturation currents. If we have kept the MOSFET switch on for more than a few hundred microseconds max, the supply will be short-circuited and the isolation of the inductor will burn off and the MOSFET will go bust and other nasty things will happen. We use our inductor knowledge to measure the time required to hit a sensible current (for example, one Amp) and then configure the oscillator on time accordingly. This results in the current waveform of the inductor having the appearance of a saw tip, hence the name saw the tooth.

3.2 MOSFET itself.

The MOSFET IRF840 is being used, sees a voltage that is the supply voltage plus the voltage of the inductor, which means the MOSFET has to be rated for a high voltage, which again implies a high resistance. The architecture of the boost converters often represents a balance between MOSFET breakdown voltage and resistance. The boost converter's MOSFET transition is always the weak point, as I have learned from dark, hard practice. The boost converter's maximum output voltage is not constrained by design but rather by the MOSFET's breakdown voltage.

3.3 AC Transformer

Limited AC transformer style 9V-12V is used in boost converter.

3.4 Output Diode

The option of diode plays a major role in efficiency at the currents we are dealing with (or even with voltage). Form diode 1N5408 is used.

3.5 Capacitor

We will use 470mf 50V condenser to render the boost converter.

3.6 Resistor

In order to calculate the maximum power point monitoring in a photovoltaic system, we will use a lot of equipment and software to make these systems use a lot of resistor such as 100, 500, 2k, 5k, 10k, etc. Resistor essentially is an electrical component that reduces electrical current. The tendency of the resistor to lower the current is called resistance and is expressed in ohms units.

3.7 Current Sensor

In this method for measuring the maximum power point tracking (MPPT) method we want to use an current sensor ACS712. To decrease the current, it is important to understand how to determine an

RMS current value from the system readings in order to use the ACS712 current sensor to measure AC current. For an ACS712 a voltage output is recorded for current measurements. We will measure the RMS volts in this tutorial and add the scale factor of ACS712 to it. The present requirements for the sensors are as follows:

- a) AC and DC current measurements
- b) Available as 5A, 20A and 30A module
- c) Provides load isolation
- d) Simple to integrate with MCU, because analog voltage outputs
- e) Scale Factor;

3.8 Voltage Sensor

In the order to regulate the maximum voltage, we must use a voltage divider circuit; the voltage divider circuits are useful in providing different voltage levels from a standard supply voltage. This common supply may be either a single supply, positive or negative, e.g. + 5V, + 12V, -5V or -12V, etc., with respect to a common point or field, generally 0V, or it may be over a dual supply, e.g. $\pm 5V$, or $\pm 12V$, etc.

Voltage dividers are often referred to as potential dividers because the voltage unit, the “Volt” reflects the potential difference between two points. A voltage or potential divider is a simple passive circuit which exploits the effect of falling voltages across components connected in sequence.

The potentiometer, which is a variable resistor with a sliding contact, is the most simple example of a voltage divider because we can apply a voltage across its terminals and generate an output voltage in relation to its sliding contact mechanical location. Yet we can also use individual resistors, condensers and inductors to create voltage dividers because they are two-terminal components that can be wired together in series. The circuit voltage divider is shown in Fig. 3.

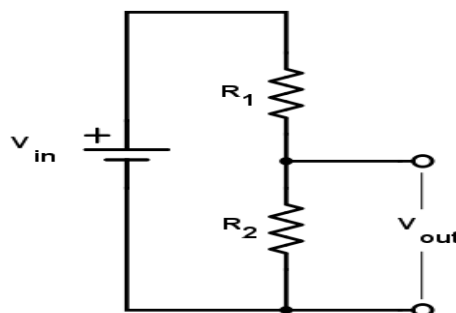

Fig. 3. Voltage Divider Circuit

3.9 Potentiometer

To vary the voltage we will use 2.5k two potentiometer in the order. A potentiometer is a passive component of electronics. Potentiometers operate by varying a sliding contact's location over a uniform resistance. The entire input voltage is applied in a potentiometer over the entire length of the

resistor, and the output voltage is the decrease in voltage between the fixed and sliding contact as shown below.

A potentiometer has the two input source terminals attached to the end of the resistor. To change the voltage level the sliding contact is pushed along the output side of the resistor as shown in Fig. 4.

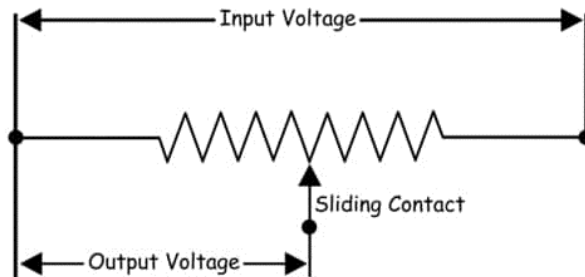

Fig. 4. Voltage divider operation

4. Simulation Model of Proposed System

Simulation model of the proposed system consists of PV arrays, boost converter, fixed duty cycle based techniques, and resistive load. Parameters and their values of the PV system are given in Table 1. Fig. 5 shows the simulation model of PV system with boost converter using fixed duty cycle and Fig.6 show the characteristics of PV System. Fig. 7 to Fig. 9 shows the input current, voltage and power characteristics of boost converter. Fig. 10 to Fig. 12 shows the output voltage, current and power characteristics of boost converter.

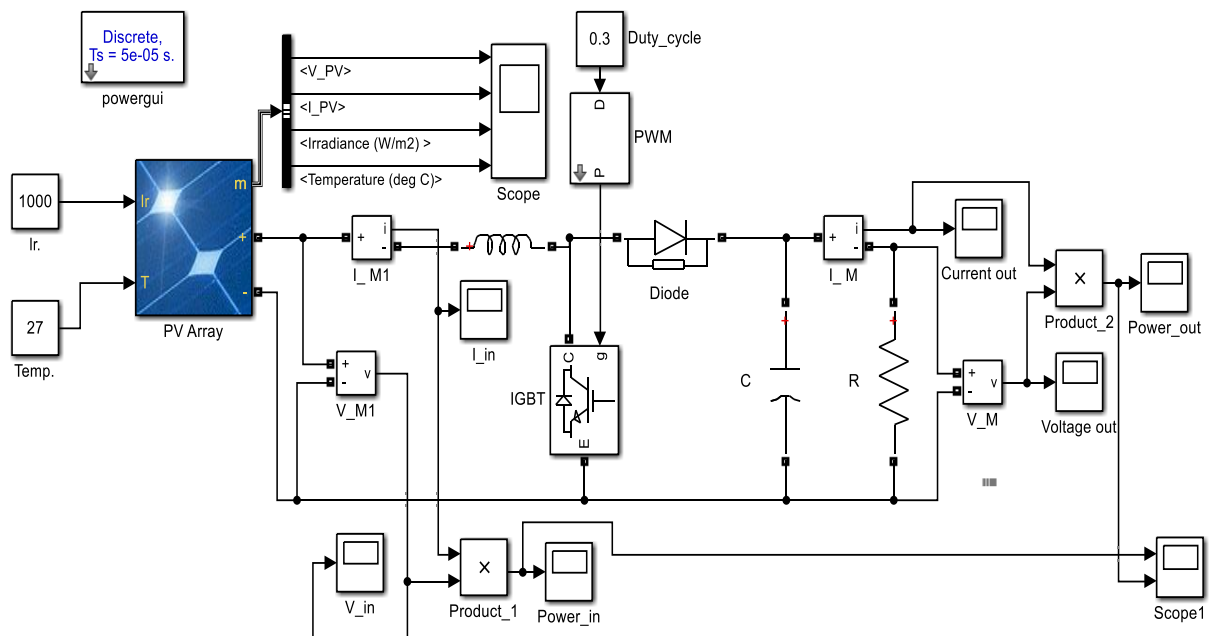

Fig. 5. Simulation Model of PV System with Fixed Duty Cycle

TABLE 1: PARAMETERS AND VALUES OF PV SYSTEM

Parameters	Values
Maximum Power (in W)	770.66
Open Circuit Voltage V_{oc} (in V)	44
Voltage at maximum power point V_{mp} (in V)	34.7
Temperature Coefficient of V_{oc} (%/ °C)	0.3583
Cell Per module (N cell)	72
Short-Circuit current I_{sc} (in A)	8.1
Current at maximum power point I_{mp} (in A)	7.8
Temperature Coefficient of I_{sc} (%/ °C)	0.024975
Light-generated current I_L (in A)	8.1924
Diode Saturation current I_o (in A)	2.4871e-10
Diode ideality factor	0.98223
Shunt resistance R_{sh} (Ω)	3126.5623
Series resistance R_s (Ω)	0.52303
Parallel strings	1
Series-connected modules per string	2

By using MATLAB software [11-14], it will show the input voltage, power and current in graphical form in this all reading it is clearly shown that the input characteristic and the output characteristics are different in Fig. 7 to Fig. 9 will show the input characteristics of current, voltage and power are fluctuated i.e. 3.7A, 120V, 245W respectively. Fig10 to 12 clearly show that the output current, voltage, and power of the boost converter are 1.5A, 160V, 270W respectively. The all process of tracking the maximum power point of the PV system it will take up to 2 sec. Output Characteristics of PV system, in this fig it is clearly seen that the output characteristics of the PV system is constant there is no any fluctuation which are accrue in the steady state of the PV system which are shown the in Fig 11. In that case it is confirmed the by using boost converter technique we will increase the output voltage of the PV system.

Simulation analysis using MATLAB is performed in order to calculate maximum power from the PV Panel. The simulation of the model has completed in two Second. Using fixed duty cycle is reduced fluctuations of outputs as compared to input results of boost converter as is clearly seen in Fig. 13.

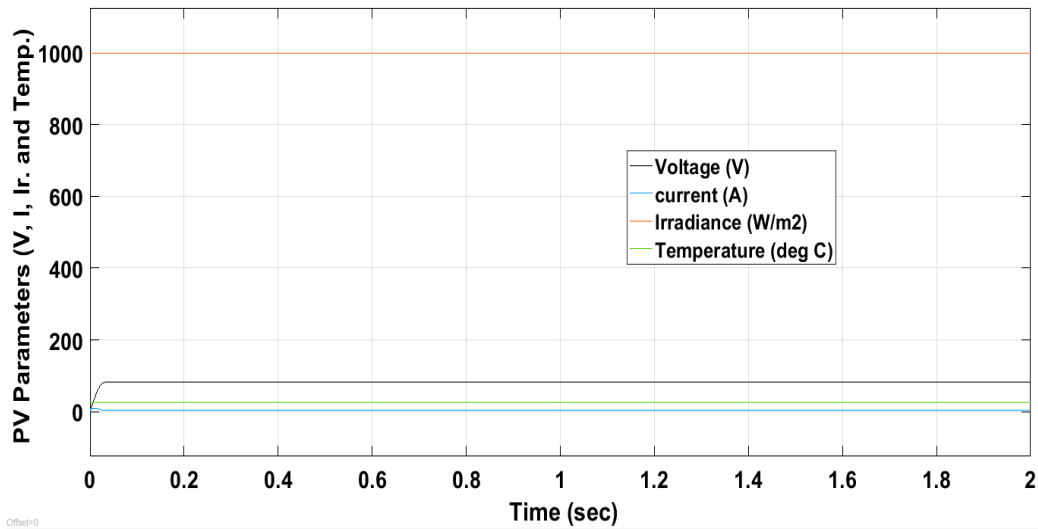

Fig. 6. Characteristics of PV system

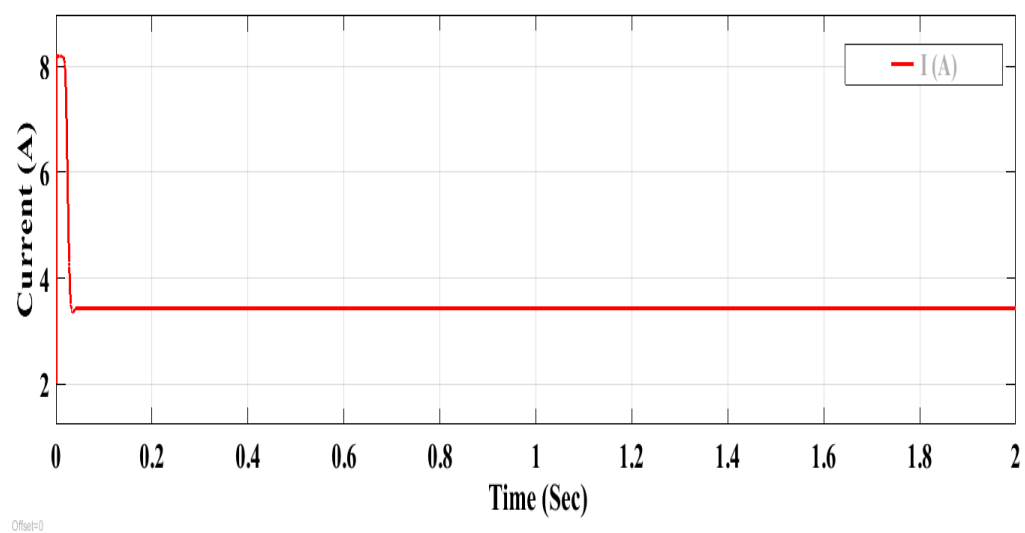

Fig.7. Characteristics of Input Current

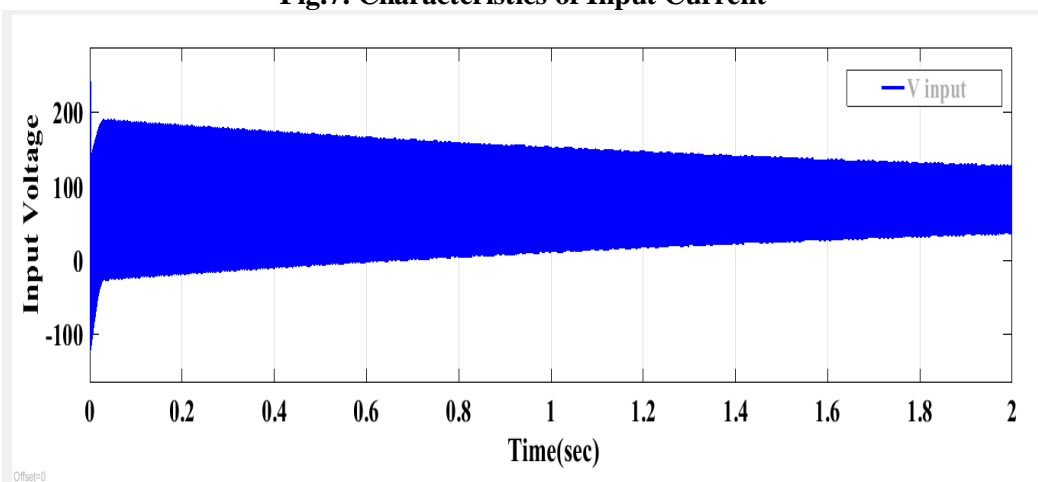

Fig.8 Characteristics of Input Voltage

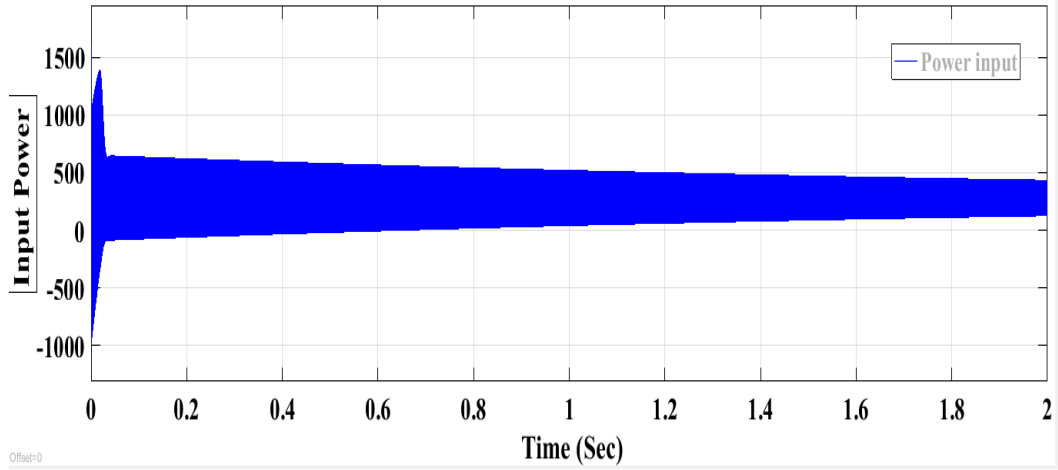

Fig. 9 Characteristics of Input Power

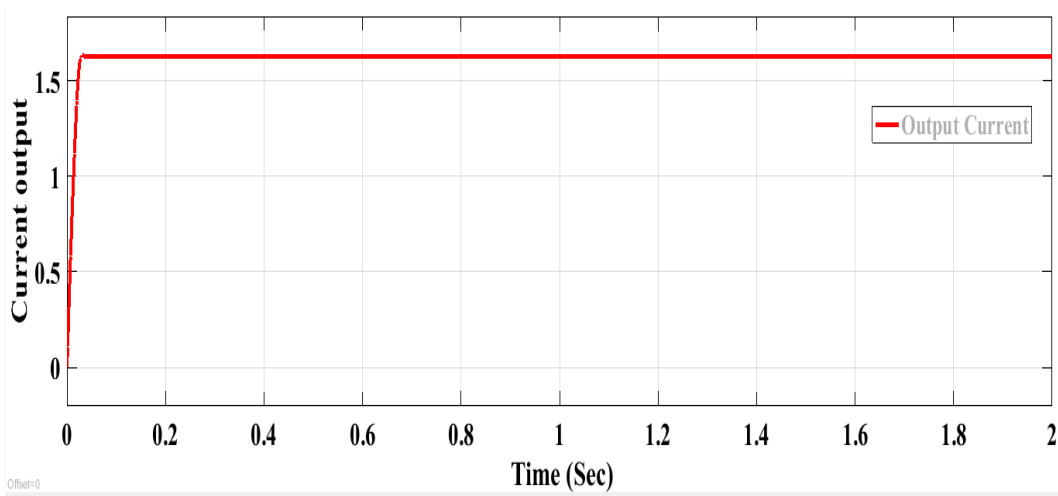

Fig.10 Characteristics of Output Current

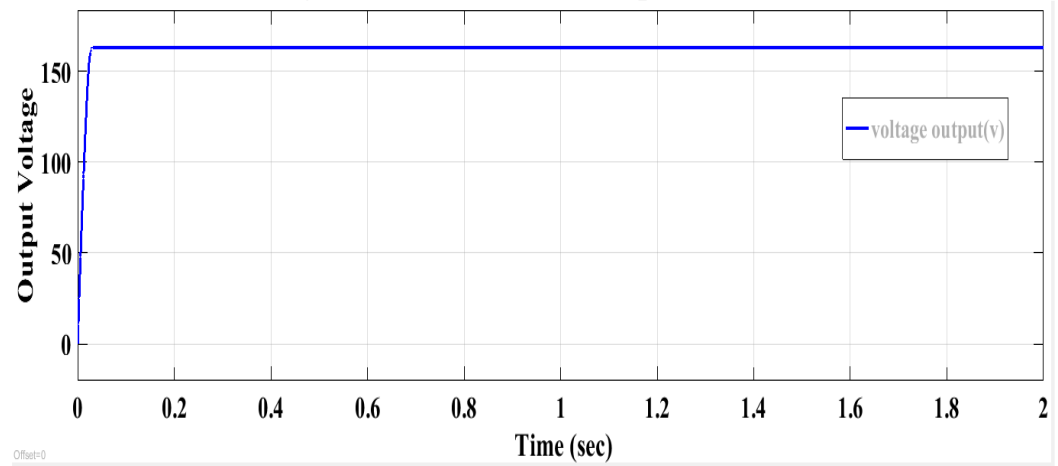

Fig.11 Characteristics of Output Voltage

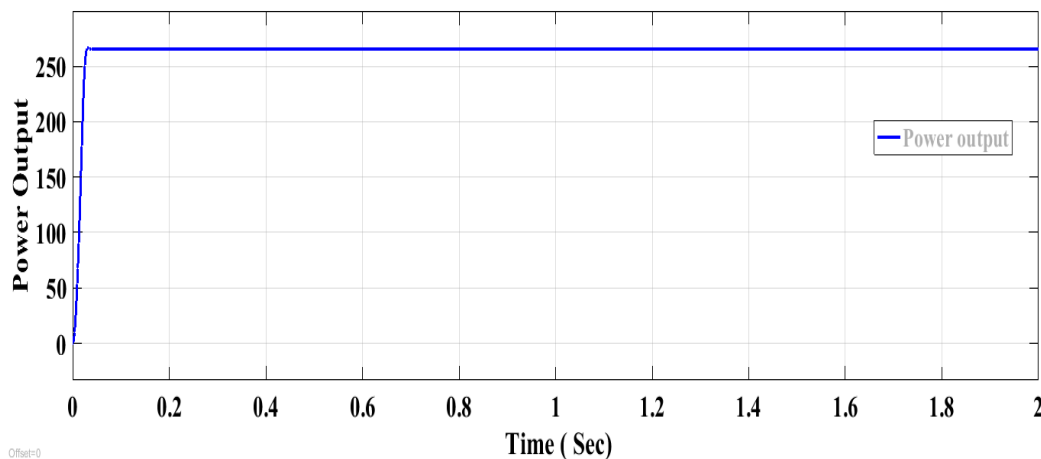

Fig.12 Characteristics of output Power

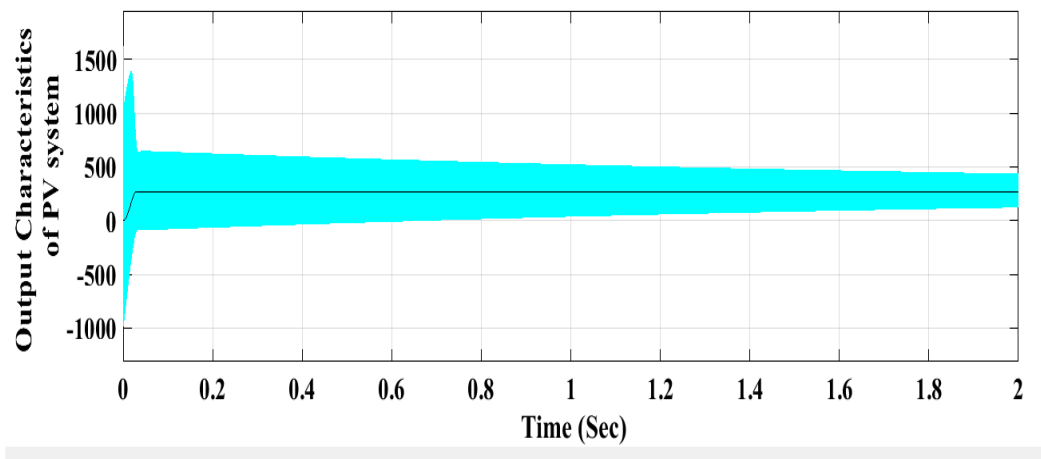

Fig. 13. Output Characteristics of PV system

5. Conclusions

Simulation analysis using MATLAB is performed in order to calculate maximum power from the PV Panel. The simulation of the model has completed in two Second. Using fixed duty cycle is reduced fluctuations of outputs as compared to input results of boost converter. In further research, any new maximum power point tracking techniques can be developed for enhancing efficiency of the PV system and also reduces the fluctuation at maximum power point.

Reference

- [1] D. Redfield, "Solar energy: Its status and prospects," CSIT Newsletter, IEEE, Vol. 4, No. 13, pp. 15-19, March 1976.
- [2] G. Spagnuolo et al., "Renewable Energy Operation and Conversion Schemes: A Summary of Discussions during the Seminar on Renewable Energy Systems," IEEE, Industrial Electronics Magazine, Vol. 4, No. 1, pp. 38-51, March 2010.
- [3] S. MekhFemia, N., Petrone, G., Spagnuolo, G. Vitelli, M., "A Technique for Improving P&O MPPT Performances of Grid-Connected Photo Voltaic Systems", IEEE Trans. Ind. Electron, Vol. 56, No. 11, pp. 4473-4482, 2009.
- [4] F. Liu, S. Duan, F. Liu, B. Liu, and Y. Kang, "A variable step size INC MPPT method for PV systems," IEEE Trans. Ind. Electron., Vol. 55, No. 7, pp. 2622–2628, 2008.

- [5] M.J. Khan and L. Mathew, “Maximum Power Point Tracking Control Method for a Hybrid PV/WT/FC Renewable Energy System,” *Serials publications, International Journal of Control Theory and Applications*, Vol. 10, No. 6, pp. 411-424, April 2017.
- [6] B. Liu, S. Duan, F. Liu, and P. Xu, “Analysis and improvement of maximum power point tracking algorithm based on incremental conductance method for photovoltaic array,” *Proc. IEEE PEDS*, 2007, pp. 637–641.
- [7] M.J. Khan and L. Mathew, “Different Kinds of Maximum Power Point Tracking control method for Photovoltaic Systems: A Review,” *Springer, Achieves of Computational Method*, pp. 1-13, 02 September 2016.
- [8] D.P.Hohm and M. E. Ropp, “Comparative Study of Maximum Power Point Tracking Algorithms Using an Experimental, Programmable, Maximum Power Point Tracking Test Bed,” *IEEE Proc. of photovoltaic specialists conference*, pp. 1699-1702, 2000.
- [9] A. Al Nabulsi and R. Dhaouadi, “Efficiency Optimization of a DSPBased Standalone PV System Using Fuzzy Logic and Dual MPPT Control,” *IEEE Trans. on Ind. Informatics*, Vol. 8, No. 3, pp. 573-584, Aug 2012.
- [10] Y. Yang, “A fuzzy logic controller for maximum power point tracking with 8-bit microcontroller,” *IEEE Proc. on Industrial Electronics Society*, Nov 2010, pp. 2895-2900.
- [11] H. Hassan, M.A. Geliel, and M. Abu-Zeid, “A proposed fuzzy controller for MPPT of a photovoltaic system,” *IEEE Proc. on Energy Conversion (CENCON)*, Oct 2014, pp. 164-169.
- [12] L.K. Letting, J.L. Munda and Y. Hamam, “Optimisation and rule firing analysis in fuzzy logic based maximum power point tracking,” *Journal of Intelligent & Fuzzy Systems*, Vol. 27, No. 3, pp. 1267-76, 2014.
- [13] E. Ganji, R.K. Moghaddam, A. Toloui and M. Taghizadeh, “A new control method for leveling output frequency fluctuations in an autonomous PV/FC/UC network with maximum power point tracking of the photovoltaic system,” *Journal of Intelligent & Fuzzy Systems*, Vol. 27, No. 4, pp. 1949-62, 2014.
- [14] P. Liu, W.T. Yang, C.E. Yang and C.L. Hsu, “Sensorless wind energy conversion system maximum power point tracking using Takagi–Sugeno fuzzy cerebellar model articulation control,” *Applied Soft Computing*, Vol. 29, pp. 450-60, 2015.