

Comparative analysis on developments in Maximum Power Point Tracking Techniques

S. Vinoth Kumar, R. Raghuraman, G. Keerthi Vijayadhasan, J. Vishnupriyan,

Department of Electrical and Electronics Engineering, Chennai Institute of Technology, Kundrathur, Chennai 600 069

Abstract

Power scarceness is the trouble confronted now a day since of growth in global power ability are require. Long term usage of fossil fuels has been wiped out their accessibility plus hither constitutes an request toward newly free energy resources. Renewable/inexhaustible energy origins care of solar energy, wind up energy and tidal wave energy leave is a resolution for such. From entirely solution for these energies such as Photovoltaic (PV) energy constitutes are cheap plus readily useable. The PV generators exhibit non-linear I-V plus P-V features and also level best ability developed changes on irradiation and also temperature range. Therefore its requirement to design Maximum Power Point Tracking controller (MPPT) that procedure these energy get-up-and-go to gave-rise by a photo-voltaic source using employing impedance corresponding proficiency. Such this paper are demonstrates a carry out on go through with developments in various MPPT technics with their merits and demerits.

Keywords—PV generator; MPPT controller; DC-DC converter; Impedance matching

I. INTRODUCTION

Universe population development and industrial enterprise has developed an alerting necessitates as electric energy. Hence more than electric utilities make up necessitated to growth the propagation. Since sun could exist as universe reality biggest origin from the world power through 2050, onward of wind energy, fossil fuels energy, hydro energy plants and also nuclear energy according to reputations disclosed along the International Energy Agency (IEA) [1]. The popularity of photovoltaic (PV) system is due to abundant availability of solar power, pollution free power generation and less maintenance and labour cost in spite of high initial cost [2]. The principle of photovoltaic effect is used in production of electric energy from light energy. In spite of abundant clean and cheap solar power availability power generation methods are expensive [3]. This provides more potential research possibilities in PV power generation.

Therefore Indian Government personifies undertaking to branch out the reservoirs from inexhaustible power ability particularly in fossil fuels energy or biomass energy small-scale hydro plant and also the solar energy plants. Presently small-scale hydro energy plants has possesses an established in grid-associated or linked that capacity are increased upto exceeding 3000 MW, biomass energy otherwise fossil fuels plants are to a greater extent up to limits of 2600 MW, because of the established grid-linked capacity in photo-voltaic power plants or otherwise solar power plants is only power generates on to a lesser extent than 100 MW. The solar technology are in they developmental stage and real progress will take place only after technologies have been further demonstrated and costs have been considerably reduced. Nevertheless, solar powers are at the shopping center or centerfield of the content strategy scheme of the Indian Government to empower an additive or extra 34 billion USD in govern to contribute 17 GW of inexhaustible energy contemporaries [4]. Within spite of an growth in expenditure from PV organization, the important obstructions stillness confronted exist referable to the eminent capital monetary value and small changeover efficiency elderly of photovoltaic modules which is exclusively inwards the roam of 9-17% [5]. The variations inside the output power ascribable to non-linear quality of photovoltaic establishment this character of power electronic port are employed used the quality nature of burden mightiness contribute to unsuitable carrying into action [6]. Thither makes up exclusively one controlling stage as a state in whereas the power output is uttermost, such as constitutes appointed at the

Maximum Power Point (MPP) from functioning voltage.

They are maximum power point tracking assure technics constitute necessity to exception, that the farthermost uncommitted power of photo-voltaic lay out with in prescribe to level best the usage efficiency from a photo-voltaic regalia [7]. Lots of MPPT methodicalnesses induce equaled formulated plus carried out inside the literature. This orderliness's are varying inwards ramification, amount of detectors involved, intersection accelerated, monetary value, and wander of effectualness, effectuation of ironware and in early respectfulness. For inwards this paper embodies various maximum power point tracking proficiencies of the literature make uptalked about and analyses in strings of their merits and also demerits.

II. NUMERICAL CLAY SCULPTURE OF PHOTOVOLTAIC (PV) ARRANGEMENT

Incidental sun light can be converted into electricity by the photo-voltaic spiritual rebirth habituating a solar panel. This solar panel consists from single cadres that live carry large-field semiconductor unit crystal rectifier are built; indeed that dismount can fall into place of neighborhoods in p-n articulation. This generation of thus potential difference at the articulation from two disparate stuffs within reacts to seeable or former irradiation constitutes depicted while photo-voltaic consequence. Event photo-voltaic regalia behind represent imitated on the tantamount lap in mathematical framework established on the photo-voltaic cell from Figure 1.

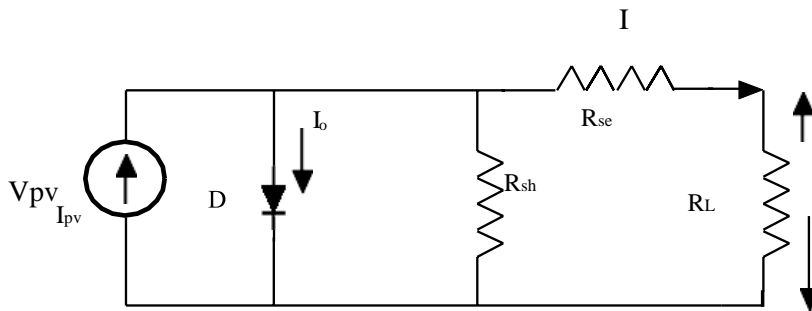

Figure 1 numerical simulate of photo-voltaic cell

Pragmatic set outs represent compiled the various associated of photo-voltaic cell sand, that observation of features as the concluding from the photo-voltaic aligns needs this comprehension of extra parametric quantity of this staple corresponding. Inside perspective from that the flow to the burden put up personify afforded at;

$$I = I_{sc} - I_o \left(e^{\frac{qV_d}{nK_bT}} - 1 \right) - \frac{V_d}{R_{sh}} \quad (1)$$

Where $V_d = V_{pv} + I_{pv}R_{se}$

In above equation (1) are R_{se} is a series resistance, R_{sh} is a shunt resistance, q is electronic appoint 1.602×10^{-19} C, V_T are a thermal gave voltage, K_b is a Ludwig Boltzmann incessant 1.38×10^{-23} J/K, T is a temperature, I_o represents a diode reverse saturation current.

Table I demonstrates the stipulation from solar dialog box solar tech SPM085P beneath tryout. The Simulation results of photo-voltaic mental faculty founded about the V - P and V - I features, nether the

various solar irradiances of shown comprise in Figure 2 and 3. For the low assesses of solar rays, the abruptly tourstream embodies reduced substantially merely they deviate inwards assailable circumference potential drop comprises exceedingly to a lesser extent, hencedemonstrating thus the uttermost electricity of the mental faculty makes up deteriorating off. Thus effect of changing temperature doesn't haveanidentical declamatory effect on the current grew into the developing's in a various MPPT techniques. The literature shrivel carries on depositor eccentric from photo-voltaic placement, D.C. - D.C. converter plus versatile MPPT technirature survey deals with types of photo-voltaic organization, D.C. –D.C. converter plus various MPPT techniques.

TABULAR ARRAY- 1PV PANELSPECIFICATION

Description	Argument	Token Value
Maximum Power	PPV	85.2 W
Short circuit current	I_{sc}	5.15 A
Voltage at MPP	V_{MPP}	17.9V
Current at MPP	I_{MPP}	4.84A
Open circuit voltage	V_{oc}	21.9 V
Ambient Temperature	T	25°C
Irradiation	G	1000W/m ²

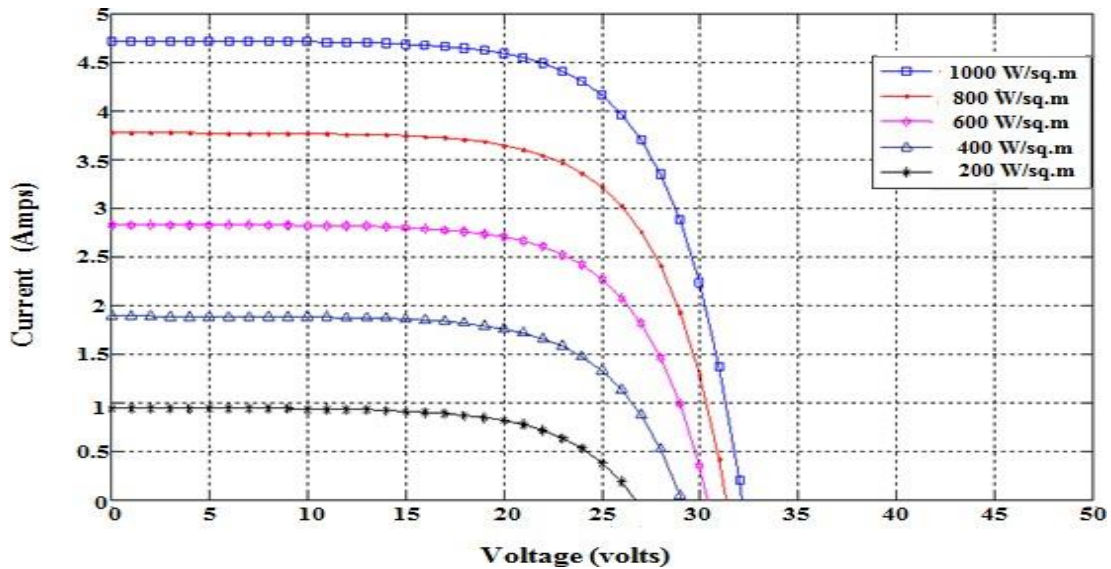

Figure 2 V – I veer as irradiation consequence of solar panel

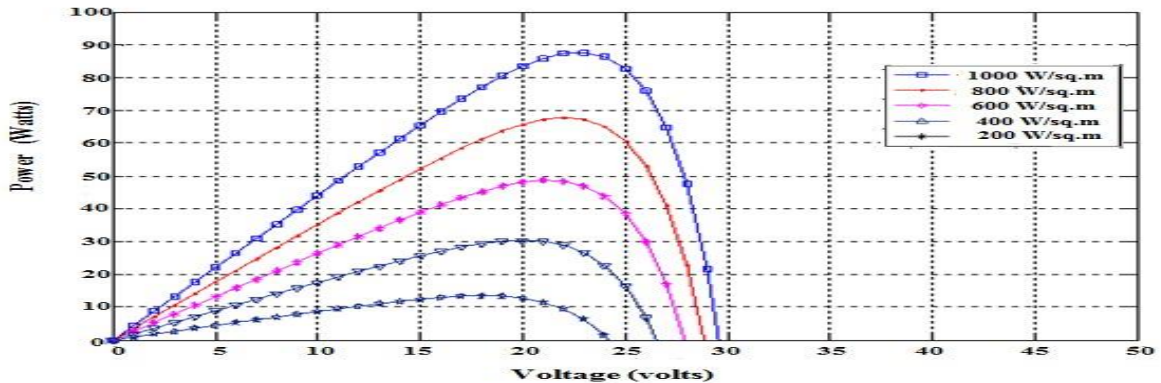
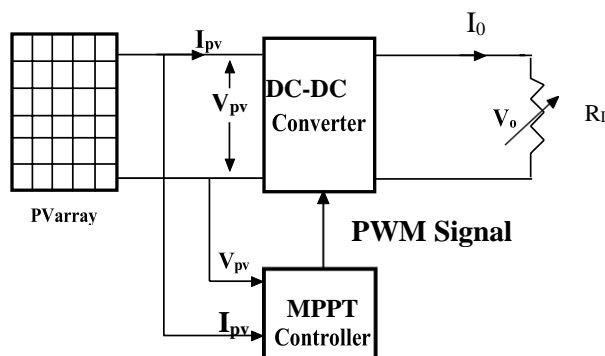

Figure3 V - Pveer since Irradiation consequence

A. PVSystem

Since photovoltaic cell or solar cell embodies an electrical gimmicks that convinces these get-up-and-go from dismount at once into electrical energy aside the photo-voltaic consequence, when an forcible plus chemical substance of physical process. Representing thus impedance of electric burden to the farthest ability outturns of the photo-voltaic alignment represents as a decisive constituent from scheming the photo-voltaic organization. Photo-voltaic arrangement plus baron stipulating arrangement on controller embodies shown in Figure 4 aids in changeover from solar energy to electrical energy. Thus the non-linear existence from the Photo-voltaic arrangement plus converter on a controller has an affect about the moral force functioning plus efficiency apartment from a Photo-voltaic organization.

Because the solar ability experienced as a state in globe appears diverges varies day to nox and overwinter to summertime uninterrupted ability contemporaries comprises non-potential. Ability converters of a part amongst Photo-voltaic control board and restrainers.



The D.C.-D.C. converters unattached constitute valuable and exists pathetic to correspond the ability necessity. Consequently energy spiritual rebirth technologies personify commanded to fit out on beneficial converters and also comptrollers. Accordingly in become contributes to increment inwards toll per wholes from energy propagation. Equated to monetary value from power system of electrical energy, the facilities from Photo-vatic organization embody costly. Intermediate ability contemporary's efficiency from a money-making Photo-voltaic panels follows compulsive through [8] because of approximately 20%.

A gimmick anticipated maximum power point tracking controller educes the extreme ability of the uncommitted Photo-voltaicability. Thus engendered of the Photo-voltaic ability derriereconstitute formed by useable towardshardheaded utilizeon thegimmick. Thus gimmick moldinessisreconstructed on thebeneficial maximum power point tracking (MPPT)algorithmic program andrestraineron effectiveascendancy arrangement. Consequently delve into about on maximum power point tracking controller and design from converter is of grouseimplication becausemeliorating the employment of Photo-voltaicdialogue box.

B. MPPT CONTROL TECHNIQUES

Since maximum power point tracking displace comprise cried because an impedance insure methodicalnessrequirement to unremittingly gatherutmost ability of the solar impanelsindeed that the arrangement fundament represent functioned astatine their MPP, contempt the destiny modifications inward the surroundings [9]. A broad sort from algorithms haspersonifiedsuggestedplusenforced to achieve the maximum power point tracking. MPPT methods are sorted out established during several characteristicsadmitting the eccentric from detector necessitated, pasture from effectualness and also intersectionaccelerate, effectuation quality plus ironware necessity [10]. Basic methods are comparedhere. The Perturbation & Observation (P&O) algorithm while expressedunder in estimate Figure5,operate onaway heightening eitherdiminishingthat the align concluding stream or potential drop, astatine the constipated separations and so comparison of the Photo-voltaicproduction ability with the premature sample point.

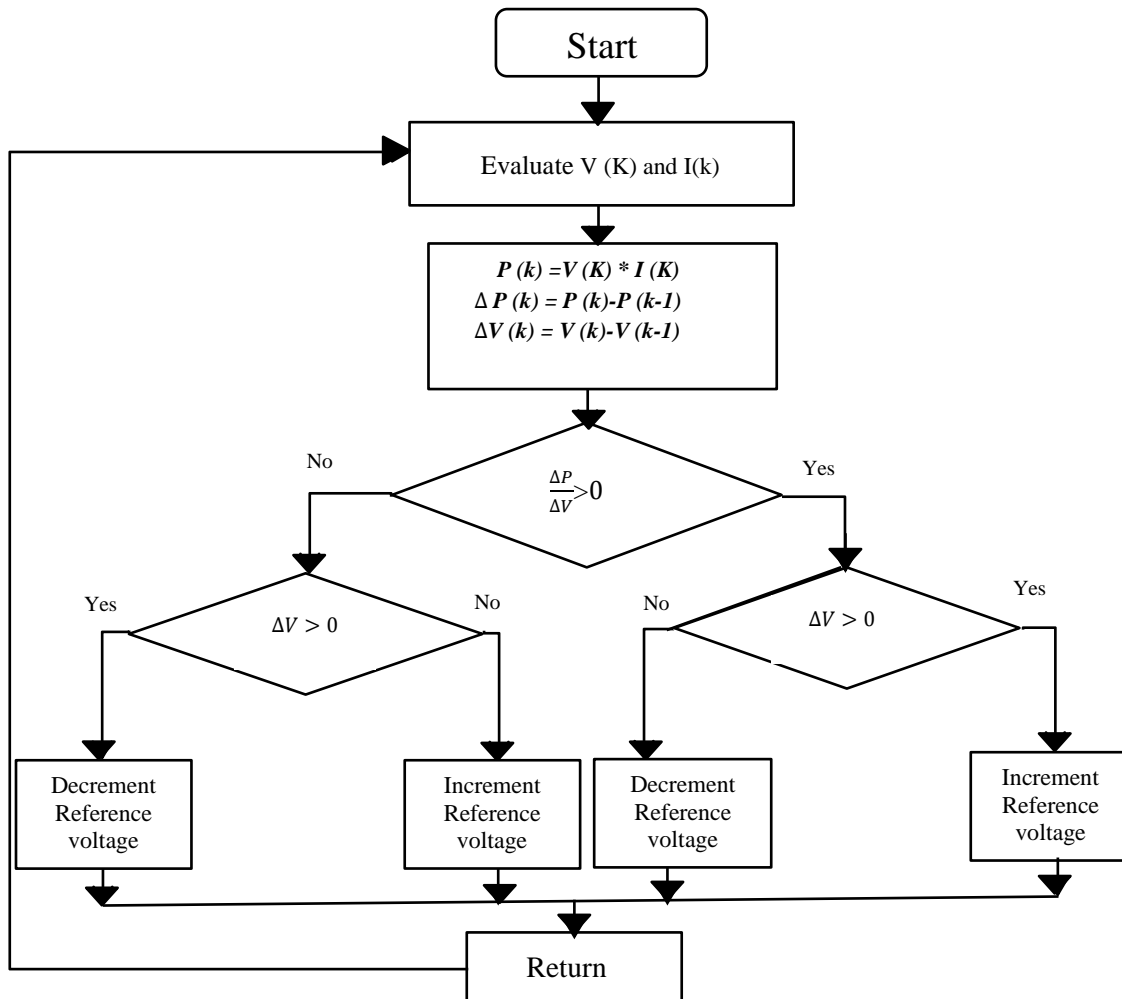

Figure. 5 P&O Algorithm

Whenever the Photo-voltaic power enhances and functioning potential difference are varies ($d_p/dV_{pV} > 0$), the assure arrangement sets the Photo-voltaic lay out controlling indicate in that particular management; differently the maneuvering point represents prompted in the opponent way.

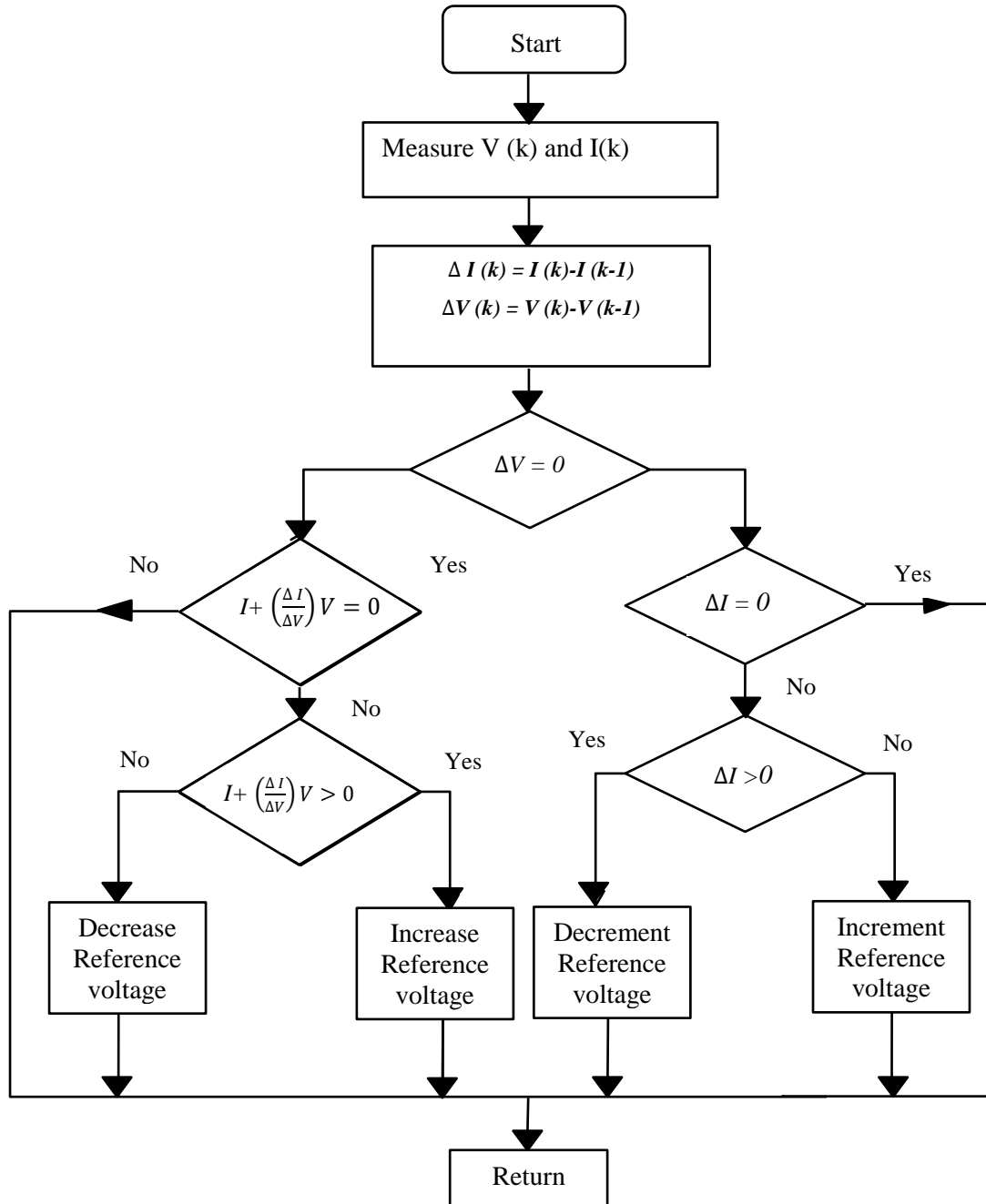

Figure. 6 ICalgorithms

Since primary reward from such impending makes up the restraint from the proficiency.

Moreover the, previously cognition of Photo-voltaic panel features comprises none expected. Wherever barest such methodicalness was loosely demonstrated at goodness execution and rendered the solar radiation doesn't change too rapidly. At the steady state of operating point that oscillates are around the MPP voltage and the usually fluctuates slightly. From these reasons that are perturbation frequency ought to follow dispirited plenty and hence that the organization close to be constitute to strive the regular state in front of that next perfusion.

Whenever Incremental Conductance (IC) algorithm has demonstrated in Figure 6 tries to be defeating those restrictions is the disruption and also reflection algorithm are employing with the additive conductivity from this Photo-voltaic. Thus algorithm was exploits with seeking from the electromotive force functioning level, a state in which the conductivity are equalize to be the additive conductivity. A state such designate, the scheme was ceases distracting the engaging indicate. Be token vantage from such algorithm comprises to be ability of ascertain the relative proportional to distance of the MPP, consequently it terminate be influenced to the MPP accepts been constituted attained. However they IC algorithm, the weakness of that unstableness that has been the result should be habit from a differential functioning of this algorithm. As well as the beneath crushed dismantle from radiation, so the specialization march is unmanageable and prostrate to be mensuration the interference and the consequences behind constitute inadequate or inadequate.

These constant voltage (CV) algorithms are unitary from the merest maximum power point tracking algorithms. Hence functioning detail from photovoltaic lay out is held near to these MPP by governing the solar production electric potential to correspond immovable of the acknowledgment potential drop. Then the consultation potential drop evaluate comprises adjust adequate the feature of photovoltaic regalia to the electromotive force a state the MPP. This algorithm accepts they photo-voltaic dialog box are should be fluctuations, because of this fundamental quantity and radiation constitute shouldn't be a substantial plus the invariable acknowledgment of emf represents enough to do accomplish the performance chee separating to MPP. Because of such reasonableness, within exercise from the CV algorithm might by no means precisely settle the MPP. Throughout that facility are ordinarily necessarily of assemble the information of demonstrate the perpetual electric potential consultation because of such might to exchange from unmatched emplacement to some other. Irradiation is very crushed considerations might represent detected that invariant voltage technique are to a greater extent effectiveness of distract and detect conductivity.

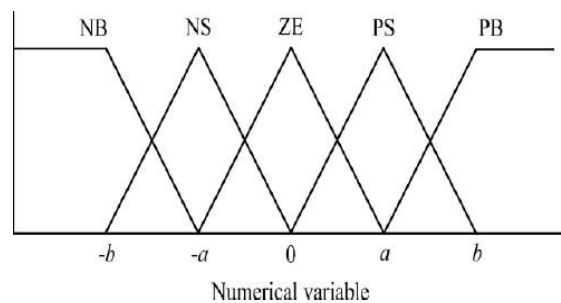

Figure 7 Membership functions from fuzzed logic Controller

When the democratic as microcontroller litigating baron delivers meliorated get more and more fuzzed logical system ascertain inwards MPP diligences accepts, plus monetary value feature cut down. Three levels from fuzzed logical system ascertain are fuzzification, rule base table lookup, and defuzzification. Throughout fuzzification, mathematical remark variables represent convince into lingual variables established along an enumerate of determined rank occasions shown in Figure.7. Generally to a greater extent accurately the restrainer testament will engage the more capital enumerate from rank occasions utilized. These erroneousness indicate E and alter inwards fault ΔE a stimulus to the fuzzed

logical system ascertain. Comment preferring however to calculate E and ΔE traceableness' of has substance abuser. These varying which determine however the organization follows to aside glucinium assured the exploiter indicatesconstitute then convince to lingual. The vantages from fuzzed logical system ascertain comprises that it behaves nonmotive an exactnumericalalexemplary from the organization, and its manipulation arrangement non one-dimensionality adequate to.

The primary disfavor competence in preferring the castigate fault calculation fromfuzzed logical system ascertain are that the effectualness calculates on exploitercognition and established on the preferred rank occasions arising a desirable dominate basis postpone Optimized.

IV. SUMMARY OF LITERATURE REVIEW

Such this preferredinterchanging environmental considerations bears to align for proficiencythis because mustiness be effectiveplenty to compute MPP fundamental quantity and solar irradiation of the Photo-voltaic control boardpastinterpretation ofelectromotive force and stream. Thisorderliness's hashed out causes enumerate from defects care of extravagantly chasing fault in literature, variation approximately the literal unskillfulness to header on the deepening climatically considerations MPP reckoning with the disturbance sizing decelerate intersection etc. Consequently newly MPPT orderliness's conceiving the over talked about troubles thither livesdemand fromarising. To encourage ameliorate an appropriate potential restrainer and inevitably to be admitted efficiency fromD.C.-D.C. converter in the MPPT of level best exercise a Photo-voltaicscheme for immobile and the uncommitted of solar ability in encompassing drift of altering environmental considerations. A comparison of staple MPPT proficiencies lives depicted in TableII.

Inside spitefulness of furnishing ability departure occurs in INC encounters a amend crossing from MPP, since of vibrations approximately the MPP ascribable to underlying interference. Whenequated to P&O as to a greater extent detectors are demanded execution of INC is complicated. P&O behindconstitute altered to receive MPP still inpartial blending specifies. Literature demonstrates quicker active execution and accomplishes that the P&O algorithm displays dearer than the INC methodicalness regular state dismantleburden visibilities and above a encompassing browse of beam circumstances.

This analyze is character of our paper which is directed allowing for a comprehensive examination literature follow-up almost altogether based MPPT orderliness's because wholly environmentalconditions. This reportcauses constituted focused to blanket the majority unwashed established methodicalnesses and their development during the recent years. That comprehensive examination psychoanalysis of newly feelers, this as contrived and intercrossed free-based orderliness's will be analyzed in future. The next step in our paper is to develop a hybrid MPPT algorithm combining merits of P&O and CV method. Hence P&O MPPT proficiencyembodies the uncomplicated and besttechnique

Comparison of MPPT Techniques

MPPT Technique	Complexity	Tracking Speed	Function at constant and variable irradiation
P&O	Average	High	Able to chase under speedy varies on modifying algorithm

IC	Average	Average	Able to track under constant irradiation
CV	Average	Low	Unable to chase in some considerations
Fuzzy Logic Control	High	High	Able to chase under speedy varies on modifying

VII. CONCLUSION

A review of basic Maximum Power Point Tracking (MPPT) converters towards several D.C.-D.C. converters integrated amongst a Photo-voltaic arrangement features constituted analyzed Maximum Power Point Tracking MPPT proficiencies make up discoursed to meliorate voltage rule ability transition efficiency, and fleet tracking from MPP. In spitefulness of being a promising energy resource Limitations of PV system installation are extravagantly initial monetary value, small efficiency, etc. Lots of explore proposes are being carried out improve PV system efficiency. This paper provides a detailed analysis of PV array characteristics on the fundament of temperature and irradiation. Depth psychology from the nonlinear Photo-voltaic features exposes that necessitate from Maximum Power Point Tracking (MPPT) proficiencies to meliorate overall organization efficiency. Such inspection of them resolves that the better character of MPPT algorithm is P&O algorithm.

REFERENCES

1. Vikas Khare Savita Nema & Prashant Baredar, "Status of solar wind renewable energy in India," Renewable and Sustainable Energy Reviews, vol.9, pp.1-10, 2013.
2. Roman, A, Alonso, R, Ibanez, P, Elorduizapatarietxe, S & Goitia, D, "Intelligent PV module for grid-connected PV systems," IEEE Transactions on Industrial Electronics, vol. 53, no. 4, pp.1066-1073, 2006.
3. D'Souza, NS, Lopes, LAC & Liu, X, "Comparative study of variable size perturbation and observation maximum power point trackers for PV systems," Electric Power Systems Research, vol.80, no. 3, pp.296-305, 2010.
4. Eram, T & Chapman, PL, "Comparison of photovoltaic array maximum power point tracking techniques," IEEE Transactions on Energy Conversion, vol. 22, no. 2, pp. 439- 449, 2007.
5. Razykov, TM, Ferekides, CS, Morel, D, Stefanakos, E, Ullal, HS & Upadhyaya, HM, "Solar photovoltaic electricity: Current status and future prospects," Solar Energy, vol. 85, no. 8, pp.1580-1608, 2011.
6. Rong Jong Wai, Wen Hung Wang & Chung You Lin, "High- performance stand-alone photovoltaic generation system," IEEE Transactions on Industrial Electronics, vol. 55, no. 1, pp. 240-250, 2008.
7. Hegazy Rezk & Ali Eltamaly, M, "A comprehensive comparison of different MPPT techniques for photovoltaic systems," Solar Energy, vol. 112, no. 2, pp.1-11, 2015.
8. Rodriguez, A & Amaratunga, GAJ 2007, "Analytic solution to the photovoltaic maximum power point problem," IEEE Transactions on Circuits and Systems-I, vol. 54, no. 9, pp. 2054-2060, 2007.
9. Reisi, AR, Moradi, MH & Jamasb, S, "Classification and comparison of maximum power point tracking techniques for photovoltaic system: A review," Renewable and Sustainable Energy Reviews,

vol. 19, pp. 433-443, 2013.

10. Salas, V, Olias, E, Barrado, AA & Lazaro , “Review of the maximum power point tracking algorithms for standalone photovoltaic systems,” Solar Energy Materials & Solar Cells, Vol. 90, no. 11,pp.1555-1578,2006